

Connettore da paratia *Wall mounting receptacle*

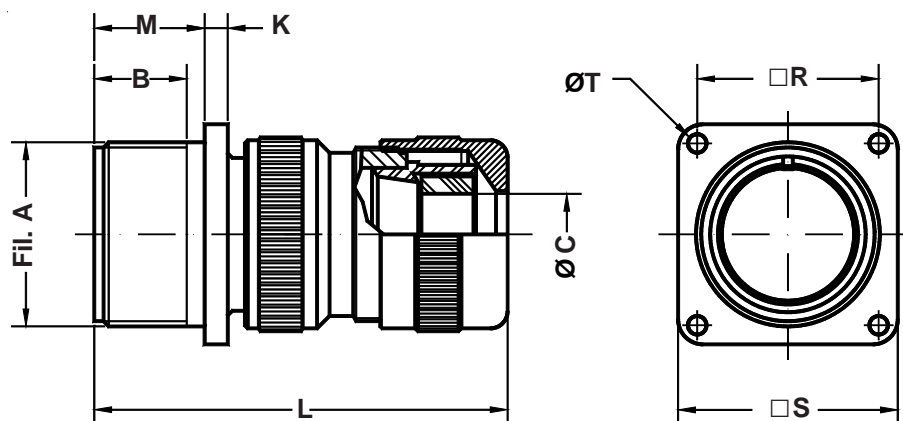

Es. / Ex. : IT3100A20-27PPHM11

Dimensione Guscio Shell Size	P.N. PHM	Filetto A A thread	B min.	C min. ÷ Max.	K ±0.2	L Max.	M +0.2 -0	R ±0.1	S ±0.2	T +0.1 -0
10 SL	9	0.6250 - 24UNEF	11	2÷9	2.8	60	14.3	18.25	25.4	3.2
12 S	11	0.7500 - 20UNEF	11	2÷11	2.8	60	14.3	20.60	27.8	3.2
12	11	0.7500 - 20UNEF	16	2÷11	2.8	60	19.1	20.60	27.8	3.2
14 S	11	0.8750 - 20UNEF	11	2÷11	3.3	60	14.5	23.00	30.0	3.2
14	11	0.8750 - 20UNEF	16	2÷11	3.3	60	19.1	23.00	30.0	3.2
16 S	11	1.0000 - 20UNEF	11	2÷11	3.3	60	14.5	24.60	32.5	3.2
16	11	1.0000 - 20UNEF	16	2÷11	3.3	70	19.1	24.60	32.5	3.2
18	11 / 18	1.1250 - 18UNEF	16	2÷11 / 9÷16.5	4.0	70	19.1	27.00	35.0	3.2
20	11 / 18	1.2500 - 18UNEF	16	2÷11 / 9÷16.5	4.0	70	19.1	29.40	38.0	3.2
22	18	1.3750 - 18UNEF	16	9÷16.5	4.0	70	19.6	31.75	41.0	3.2
24	18 / 22 / 24	1.5000 - 18UNEF	17	9÷16.5 / 15÷20 / 19÷24	4.0	80	20.6	34.90	44.5	3.7
28	18 / 22 / 24	1.7500 - 18UNS	17	9÷16.5 / 15÷20 / 19÷24	4.0	80	20.0	39.70	50.9	3.7
32	22 / 24	2.0000 - 18UNS	17	15÷20 / 19÷24	4.0	80	22.3	44.45	57.0	4.3
36	35	2.2500 - 16UN	17	23÷35	4.0	95	22.3	49.20	63.5	4.3
40	35	2.5000 - 16UN	17	23÷35	4.0	95	22.3	55.55	69.9	4.3

Connettore da pannello flangia quadra.
Fornito completo di serracavo PHM. Garantisce una ottima tenuta meccanica sul cavo e ambientale se provvisto di appositi O-Ring.

Wall mounting receptacle.
Includes a PHM cable clamp that assures an excellent mechanical and waterproof seal if used with the correct neoprene sealing sleeves.
No grommet supplied.