

Moistureproof Data Cable Hummer Adapters RFI/EMI, Shield Termination, Shrink Boot, Metal, For Series 74 Conduit - 710S645

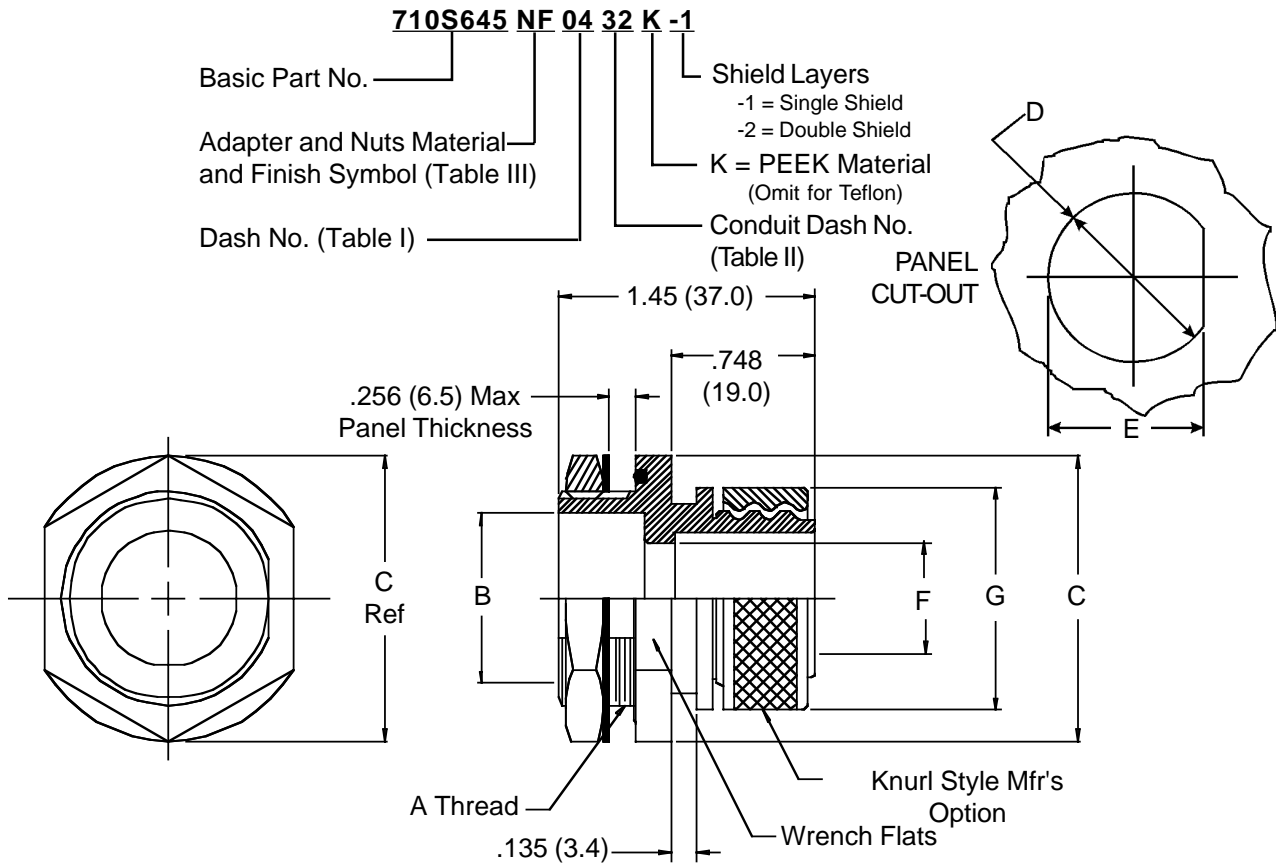

TABLE I

Dash No.	A Thread Iso Metric	B Dia	C Max	D Dia	E Ref	Max Conduit Dash No. Table II
01	M16 X 1.5 - 6g	.394 (10.0)	.827 (21.0)	.640 (16.3)	.593 (15.1)	12
02	M20 X 1.5 - 6g	.551 (14.0)	1.063 (27.0)	.802 (20.4)	.755 (19.2)	16
03	M27 X 2.0 - 6g	.949 (24.1)	1.496 (38.0)	1.077 (27.4)	1.027 (26.1)	28
04	M36 X 2.0 - 6g	1.181 (30.0)	1.850 (47.0)	1.438 (36.5)	1.388 (35.3)	32

TABLE II

Conduit Dash No.	F ±.010 (.3)	G Max	Raychem Shrink Boot Part No.
09	.281 (7.1)	.79 (20.1)	202K132-100/180-0
12	.375 (9.5)	.89 (22.6)	202K132-100/180-0
16	.500 (12.7)	1.03 (26.2)	202K142-100/180-0
20	.625 (15.9)	1.15 (29.2)	202K142-100/180-0
24	.750 (19.1)	1.31 (33.3)	202K153-100/180-0
28	.875 (22.2)	1.43 (36.3)	202K163-100/180-0
32	1.000 (25.4)	1.60 (40.6)	202K174-100/180-0

TABLE III

Symbol	Finish Description	Material
B	Cadmium Olive Drab	Aluminum
M	Electroless Nickel	Aluminum
N	Cadmium Olive Drab Over Electroless Nickel	Aluminum
NF	Cadmium Olive Drab Over Electroless Nickel (500 Hr. Salt Spray)	Aluminum
ZN	Zinc Nickel Olive Drab Over	Aluminum
Z1	Passivated	Stainless Steel
BM	Electroless Nickel	Brass
BN	Cadmium Olive Drab Over Electroless Nickel (500 Hr. Salt Spray)	Brass
BO	No Plating	Brass

1. Metric dimensions (mm) are indicated in parentheses.
2. Materials:
Adapter, Hex Nut, and Rear Nut - See Table III.
Washer - Cres/Passivate. O-Ring - Silicone.