



637-031 Composite RFI/EMI Environmental Feed-Through Jam-Nut Mount Accessory Adapter

**For Use with MIL-
DTL-38999 Series
III and IV Acces-
sory Threads
(Glenair Code H)**

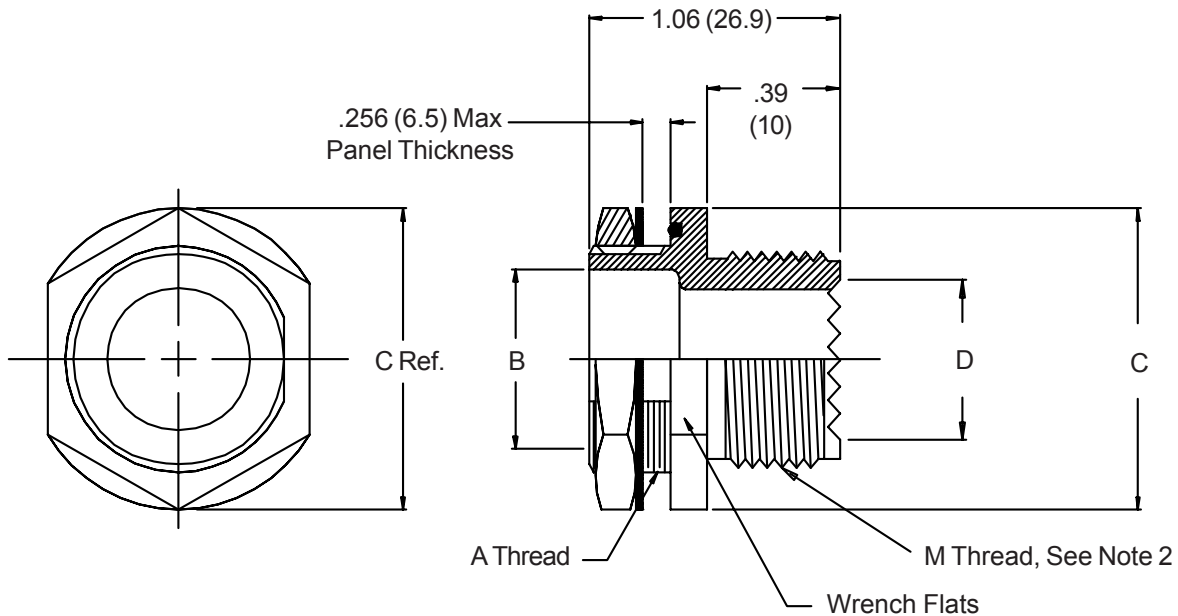
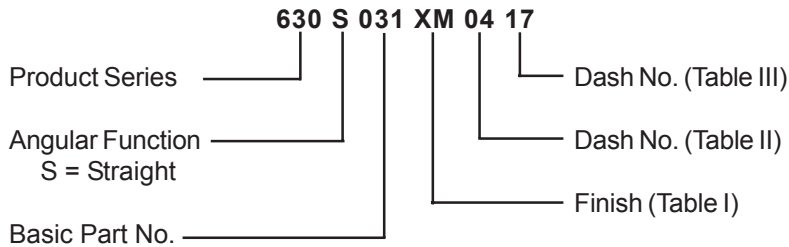

TABLE I

XM	Electroless Nickel
XW	Cadmium Olive Drab Over Electroless Nickel

TABLE II

Dash No.	A Thread ISO Metric	B Dia. Min.	C Max.	Max Entry Table 3
01	M 16 x 1.5-6g	.394 (10.0)	1.024 (26.0)	11
02	M 20 x 1.5-6g	.551 (14.0)	1.181 (30.0)	13
03	M 27 x 2.0-6g	.866 (22.0)	1.496 (38.0)	21
04	M 36 x 2.0-6g	1.181 (30.0)	1.850 (47.0)	25

TABLE III

Dash No.	M Thread ISO Metric	D Min
09	M 12 x 1.0-6g	.250 (6.4)
11	M 15 x 1.0-6g	.375 (9.5)
13	M 18 x 1.0-6g	.500 (12.7)
15	M 22 x 1.0-6g	.625 (15.9)
17	M 25 x 1.0-6g	.750 (19.1)
19	M 28 x 1.0-6g	.812 (20.6)
21	M 31 x 1.0-6g	.938 (23.8)
23	M 34 x 1.0-6g	1.062 (27.0)
25	M 37 x 1.0-6g	1.188 (30.2)

1. Metric dimensions (mm) are indicated in parentheses.
2. MIL-C-38999 Series 3 & 4 Accessory Interface, Glenair Code H.