

RFI/EMI
Environmental
with External
Banding Porch

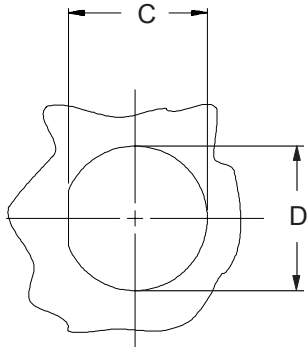

Type A
Rear Mount

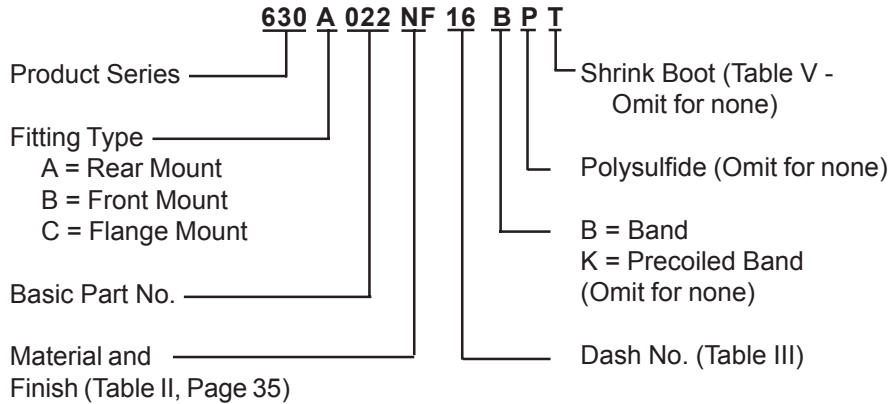
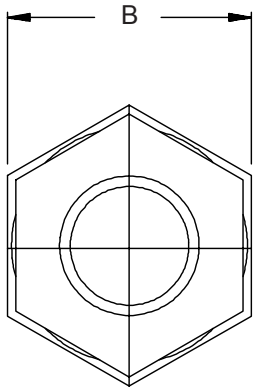
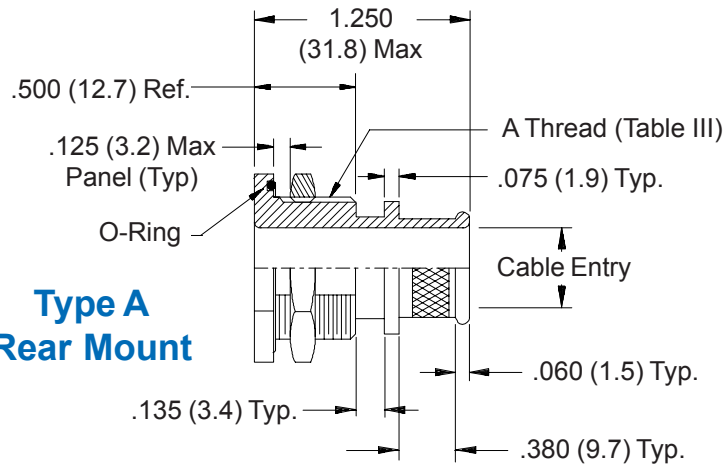

Type B
Front Mount

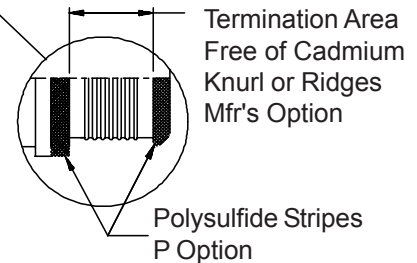
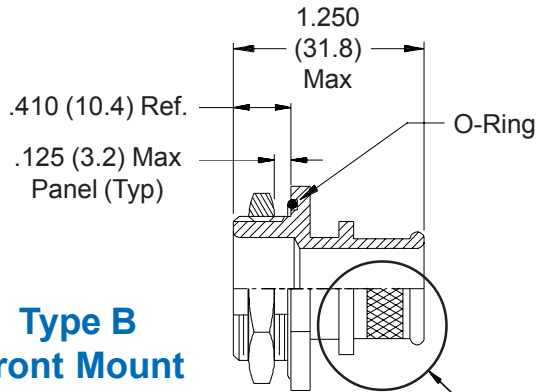

630-022 Feed-Through Fittings Banding Adapter RFI/EMI Environmental



Feed-Through Fittings

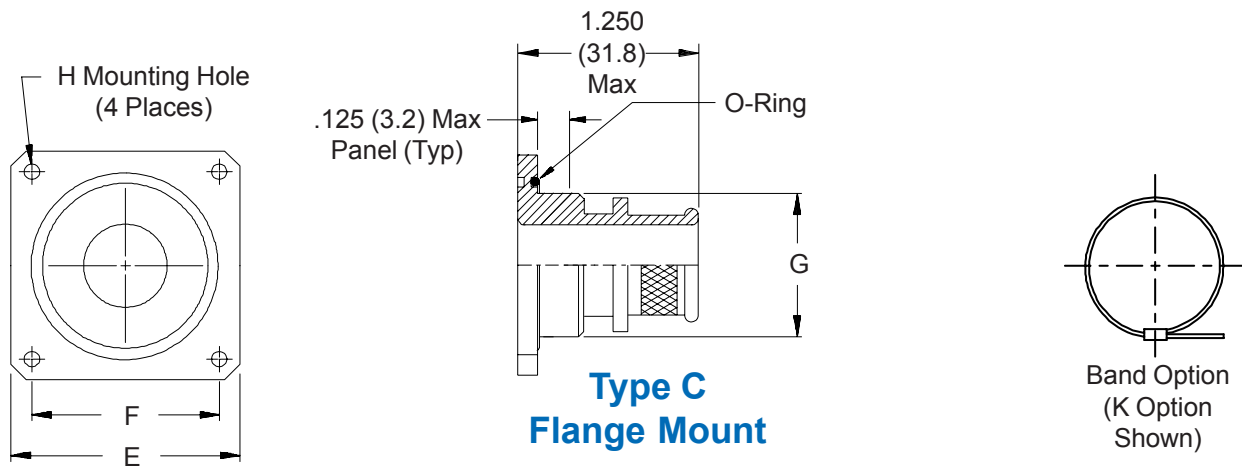

**Type C
Flange Mount**

Band Option
(K Option
Shown)

TABLE III

Dash No.	Cable Entry Dia	A Thread Unified	B Dim	C Flat ± .010 (± .3)	D Dia ± .010 (± .3)	E Sq ± .031 (± .8)	F Dim.	G Dia	
								+ .005 (+ .1)	- .015 (- .4)
03	.188 (4.8)	1/2 -28	.688 (17.5)	.480 (12.2)	.515 (13.1)	.875 (22.2)	.594 (15.1)	.500 (12.7)	
04	.250 (6.4)	1/2 -28	.688 (17.5)	.480 (12.2)	.515 (13.1)	.875 (22.2)	.594 (15.1)	.500 (12.7)	
05	.313 (8.0)	5/8 -24	.813 (20.7)	.605 (15.4)	.640 (16.3)	1.000 (25.4)	.719 (18.3)	.625 (15.9)	
06	.375 (9.5)	5/8 -24	.813 (20.7)	.605 (15.4)	.640 (16.3)	1.000 (25.4)	.719 (18.3)	.625 (15.9)	
07	.438 (11.1)	3/4 -20	.938 (23.8)	.730 (18.5)	.765 (19.4)	1.094 (27.8)	.812 (20.6)	.750 (19.1)	
08	.500 (12.7)	3/4 -20	.938 (23.8)	.730 (18.5)	.765 (19.4)	1.094 (27.8)	.812 (20.6)	.750 (19.1)	
09	.563 (14.3)	7/8 -20	1.063 (27.0)	.855 (21.7)	.890 (22.6)	1.188 (30.2)	.906 (23.0)	.875 (22.2)	
10	.625 (15.9)	7/8 -20	1.063 (27.0)	.855 (21.7)	.890 (22.6)	1.188 (30.2)	.906 (23.0)	.875 (22.2)	
11	.688 (17.5)	1 -20	1.188 (30.2)	.980 (24.9)	1.015 (25.8)	1.281 (32.5)	.969 (24.6)	1.000 (25.4)	
12	.750 (19.1)	1 -20	1.188 (30.2)	.980 (24.9)	1.015 (25.8)	1.281 (32.5)	.969 (24.6)	1.000 (25.4)	
13	.813 (20.7)	1 1/8 -18	1.313 (33.4)	1.105 (28.1)	1.140 (29.0)	1.375 (34.9)	1.062 (27.0)	1.125 (28.6)	
14	.875 (22.2)	1 1/4 -18	1.438 (36.5)	1.230 (31.2)	1.265 (32.1)	1.500 (38.1)	1.156 (29.4)	1.250 (31.8)	
15	.938 (23.8)	1 1/4 -18	1.438 (36.5)	1.230 (31.2)	1.265 (32.1)	1.500 (38.1)	1.156 (29.4)	1.250 (31.8)	
16	1.000 (25.4)	1 3/8 -18	1.563 (39.7)	1.355 (34.4)	1.390 (35.3)	1.625 (41.3)	1.250 (31.8)	1.375 (34.9)	
17	1.063 (27.0)	1 3/8 -18	1.563 (39.7)	1.355 (34.4)	1.390 (35.3)	1.625 (41.3)	1.250 (31.8)	1.375 (34.9)	
18	1.125 (28.6)	1 1/2 -18	1.688 (42.9)	1.480 (37.6)	1.515 (38.5)	1.750 (44.5)	1.375 (34.9)	1.500 (38.1)	
19	1.188 (30.2)	1 1/2 -18	1.688 (42.9)	1.480 (37.6)	1.515 (38.5)	1.750 (44.5)	1.375 (34.9)	1.500 (38.1)	
20	1.250 (31.8)	1 5/8 -18	1.813 (46.1)	1.605 (40.8)	1.640 (41.7)	1.812 (46.0)	1.500 (38.1)	1.625 (41.3)	
22	1.375 (34.9)	1 3/4 -18	1.938 (49.2)	1.730 (43.9)	1.765 (44.8)	2.000 (50.8)	1.562 (39.7)	1.750 (44.5)	
24	1.500 (38.1)	2 -18	2.188 (55.6)	1.980 (50.3)	2.015 (51.2)	2.250 (57.2)	1.750 (44.5)	2.000 (50.8)	
26	1.625 (41.3)	2 -18	2.188 (55.6)	1.980 (50.3)	2.015 (51.2)	2.250 (57.2)	1.750 (44.5)	2.000 (50.8)	
28	1.750 (44.5)	2 1/4 -16	2.438 (61.9)	2.230 (56.6)	2.265 (57.5)	2.500 (63.5)	1.938 (49.2)	2.250 (57.2)	

TABLE IV

Dash Nos.	H Dia	
	+ .015 (+ .4)	- .000 (- .0)
03-17	.125 (3.2)	
18-20	.156 (4.0)	
22-28	.188 (4.8)	

TABLE V

Dash Nos.	Shrink Boot (Note 2)
03-06	202K121-25-0
07-10	202K132-25-0
11-12	202K142-25-0
13-16	202K153-25-0
17-20	202K163-25-0
22-26	202K174-25-0
28	202K185-25-0

1. Metric dimensions (mm) are indicated in parentheses.
2. Raychem shrink boot supplied with "T" option (see part number development).