

**Cable Shield
Grounding Assembly
Female Pipe Thread - GA/CSGA-*/NPT**

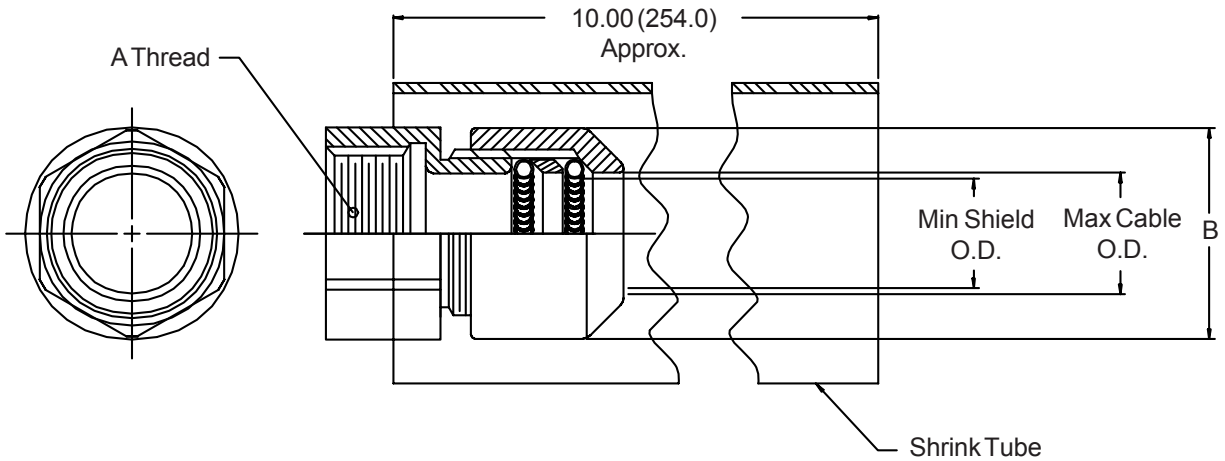

TABLE II

Part Number	A Thread	Max Cable O.D.	Min Shield O.D.	B Max	Shrink Tube Part Number
GA/CSGA-1A/NPT	3/8 - 18 NPT	.406 (10.3)	.200 (5.1)	1.12 (28.4)	HRSR 125
GA/CSGA-2B/NPT	1/2 - 14 NPT	.515 (13.1)	.260 (6.6)	1.12 (28.4)	HRSR 125
GA/CSGA-3C/NPT	3/4 - 14 NPT	.640 (16.3)	.400 (10.2)	1.32 (33.5)	HRSR 175
GA/CSGA-3D/NPT	3/4 - 14 NPT	.750 (19.1)	.400 (10.2)	1.63 (41.4)	HRSR 175
GA/CSGA-4E/NPT	1 - 11 1/2 NPT	.812 (20.6)	.430 (10.9)	1.63 (41.4)	HRSR 175
GA/CSGA-4F/NPT	1 - 11 1/2 NPT	.843 (21.4)	.470 (11.9)	1.75 (44.5)	HRSR 200
GA/CSGA-4G/NPT	1 - 11 1/2 NPT	.953 (24.2)	.580 (14.7)	1.88 (47.8)	HRSR 200
GA/CSGA-5J/NPT	1 1/4 - 11 1/2 NPT	1.062 (27.0)	.690 (17.5)	1.88 (47.8)	HRSR 200
GA/CSGA-5K/NPT	1 1/4 - 11 1/2 NPT	1.172 (29.8)	.800 (20.3)	2.06 (52.3)	HRSR 250
GA/CSGA-5L/NPT	1 1/4 - 11 1/2 NPT	1.265 (32.1)	.890 (22.6)	2.18 (55.4)	HRSR 250
GA/CSGA-6M/NPT	1 1/2 - 11 1/2 NPT	1.406 (35.7)	1.010 (25.7)	2.32 (58.9)	HRSR 250
GA/CSGA-6N/NPT	1 1/2 - 11 1/2 NPT	1.515 (38.5)	1.130 (28.7)	2.38 (60.5)	HRSR 250
GA/CSGA-7P/NPT	2 - 11 1/2 NPT	1.625 (41.3)	1.130 (28.7)	2.44 (62.0)	HRSR 250
GA/CSGA-7R/NPT	2 - 11 1/2 NPT	1.750 (44.5)	1.250 (31.8)	2.75 (69.9)	HRSR 300
GA/CSGA-7S/NPT	2 - 11 1/2 NPT	1.875 (47.6)	1.380 (35.1)	2.88 (73.2)	HRSR 300
GA/CSGA-8T/NPT	2 1/2 - 8 NPT	2.062 (52.4)	1.560 (39.6)	3.13 (79.5)	HRSR 400
GA/CSGA-8V/NPT	2 1/2 - 8 NPT	2.187 (55.5)	1.690 (42.9)	3.25 (82.6)	HRSR 400

1. Metric dimensions (mm) are indicated in parentheses.

2. Material/Finish:

Adapters - Al Alloy/Cadmium Olive Drab Over Electroless Nickel (500 Hour Salt Spray).*

Ferrule and Grounding Springs - Cres/Passivate.

Tubing - Heat Shrinkable, Flame Retardant, With Adhesive.

*Available in Passivated 316 Stainless Steel, add 49A to end of part number.