

M24758/14 Adapter for MIL-C-28840 (EC) Backshells

M24758/14-16-01-01-A

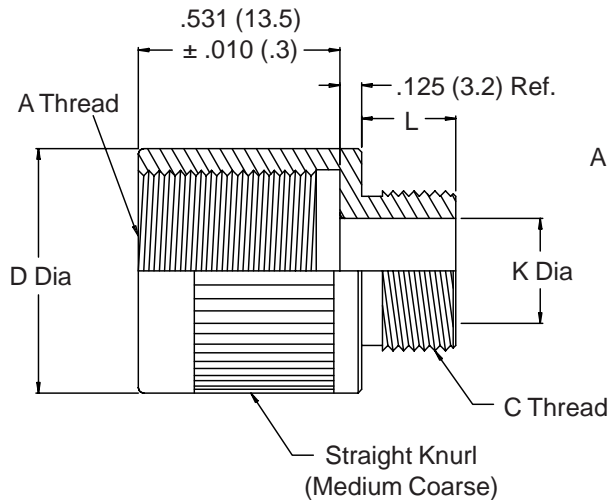

STYLE 01
FOR USE WHEN K DIAMETER IS
SMALLER THAN E DIAMETER

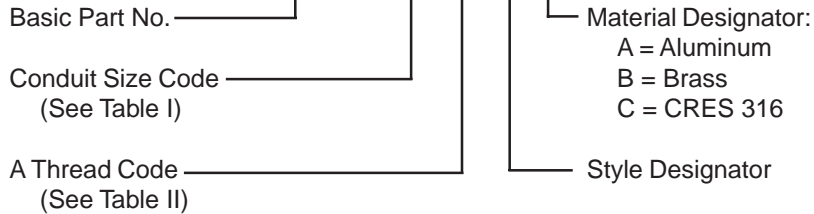
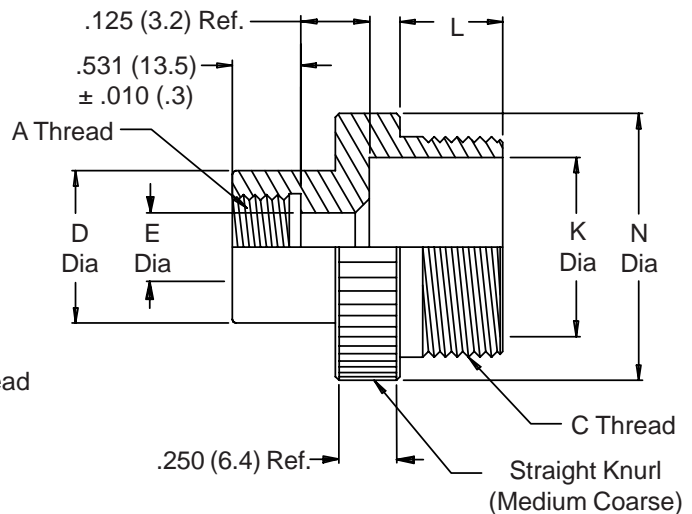

STYLE 02
FOR USE WHEN K DIAMETER
IS EQUAL TO OR LARGER THAN E DIAMETER

1. The M24758/14 adapter provides a non-environmental coupling between certain MIL-C-28840 (EC) backshells and the M24758/2, M24758/3 or M24758/4 fittings, specifically, the A-thread of this adapter mates with the V-thread of the M28840/6 backshell (straight), the M28840/8 backshell (90°), or the M28840/9 backshell (45°).
2. Metric dimensions (mm) are indicated in parentheses.
3. For complete dimensions see applicable Military Specification.

M24758/14 Adapter for
MIL-C-28840 (EC) Backshells



TABLE I

Conduit Size Code	C Thread (Class 2A)	L		K Dia Min.		N Dia	
		±.02	(.5)			±.02	(.5)
02	0.438 - 28 UNEF	.210	(5.3)	.250	(6.4)	.687	(17.4)
03	0.563 - 24 UNEF	.250	(6.4)	.370	(9.4)	.812	(20.6)
04	0.688 - 24 UNEF	.250	(6.4)	.500	(12.7)	.937	(23.8)
05	0.813 - 20 UNEF	.310	(7.9)	.620	(15.7)	1.062	(27.0)
06	0.938 - 20 UNEF	.310	(7.9)	.750	(19.1)	1.187	(30.1)
08	1.250 - 18 UNEF	.370	(9.4)	1.000	(25.4)	1.500	(38.1)
10	1.563 - 18 UNEF	.370	(9.4)	1.250	(31.8)	1.812	(46.0)
12	1.875 - 16 UN	.430	(10.9)	1.500	(38.1)	2.125	(54.0)
16	2.375 - 16 UN	.430	(10.9)	2.000	(50.8)	2.625	(66.7)
20	2.875 - 16 UN	.430	(10.9)	2.500	(63.5)	3.125	(79.4)
24	3.375 - 16 UN	.430	(10.9)	3.000	(76.2)	3.625	(92.1)

TABLE II (A Thread Code and Adapter Dimensions)

A Thread Code	Shell Size (Ref.)	A Thread (Class 2B)	D Dia		E Dia	
			±.015	(.4)	±.015	(.4)
01	B, C	0.625 - 24 UNEF	.875	(22.2)	.435	(11.0)
02	B, C	0.750 - 20 UNEF	1.000	(25.4)	.578	(14.7)
03	C	0.875 - 20 UNEF	1.125	(28.6)	.703	(17.9)
04	D, E	1.000 - 20 UNEF	1.250	(31.8)	.828	(21.0)
05	C, D, F	1.188 - 18 UNEF	1.438	(36.5)	1.000	(25.4)
06	D, E, F, G	1.438 - 18 UNEF	1.688	(42.9)	1.250	(31.8)
07	F, G, H	1.750 - 18 UNS	2.000	(50.8)	1.562	(39.7)
08	G, H, J	2.000 - 18 UNS	2.250	(57.2)	1.813	(46.1)
09	J	2.250 - 16 UN	2.250	(57.2)	2.062	(52.4)
10	C, D, E	1.125 - 18 UNEF	1.375	(34.9)	.938	(23.8)
11	C, D, E, F, G	1.250 - 18 UNEF	1.500	(38.1)	1.078	(27.4)
12	D, E, F, G	1.626 - 18 UNEF	1.875	(47.6)	1.438	(36.5)
13	F, G, H	1.875 - 18 UNS	2.125	(54.0)	1.688	(42.9)
14	G, H, J	2.125 - 16 UN	2.375	(60.3)	1.938	(49.2)
15	J	2.750 - 16 UN	3.000	(76.2)	2.563	(65.1)