



Introduction to *High-Speed, Balanced Impedance Connectors and Cables for SATA and Other Differential Data Bus Applications*



High speed, High Bandwidth Performance for Military Grade Connectors and Cables

In response to requests for ruggedized, shielded connectors and cables to replace unshielded systems for high-speed serial data, Glenair developed its Mighty Mouse line of high speed serial data cordsets. Available for 100BASE-T, 1000BASE-T Gigabit Ethernet, IEE 1394, USB 2.0 and CAN Bus applications, these cordsets combined aerospace-grade data cables with Series 80 Mighty Mouse harsh environment connectors for maximum performance and minimum size. These cables, which used our standard Series 80 Mighty Mouse connectors with LCP insulators, have been successfully used in hundreds of Ethernet and other high speed data protocol applications. Now Glenair is proud to introduce our latest *High-Speed* Mighty Mouse innovation, a DuPont™ Teflon® PFA Insulator equipped Mighty Mouse connector series that delivers even better impedance, VSWR and insertion loss performance in 100 Ohm, balanced impedance applications.

High Speed Performance	
Impedance	100 OHMS \pm 7 OHMS at 100-Picosecond
VSWR	<1.4 up to 4-GHz

Insertion Loss	
1 GHz	.51 dB
2 GHz	.53 dB
3 GHz	.57 dB
4 GHz	1.2 dB
5 GHz	1.25 dB

special PFA (Teflon) insulator-equipped connectors, combined with our high-performance high-speed differential 859-041 Series cable, deliver performance levels not available in other ultraminiature military-grade interconnection assemblies.



Next-Generation Series 80 Mighty Mouse Connectors with DuPont™ Teflon® PFA Insulators

The new *High-Speed* Mighty Mouse connectors and ASAP cordsets presented in this catalog offer the same space and weight savings as our original LCP versions with superior performance in SATA and 2, 3, and 4 pair differential cable applications. These miniaturized connectors and cordsets are ideal for ultra high bandwidth data switches requiring high density packaging. Performance measurements for impedance, VSWR and insertion loss indicate that the

High-Speed Data Protocols

Ethernet

Avionic and other military vehicle data transfer systems are growing increasingly complicated—the number of data paths, data rates and the quantity and sophistication of subsystems continue to escalate. In addition to transmission speed, accuracy and reliability are tremendously important. Ethernet communication technology, with its huge installed base and history of reliability, is ideally suited for military vehicles and other field applications. Although there are many MIL-STD-1553 bus architecture and data link systems in use, applications such as tactical radar require faster data rates than older architectures can deliver.

Basic Ethernet protocol is referred to as “CSMA/DC” (Carrier Sense, Multiple Access and Collision Detection). To define some terms: “Carrier Sense,” the hosts can detect whether the medium is idle or busy;

Introduction to *High-Speed, Balanced Impedance* Connectors and Cables for SATA and Other Differential Data Bus Applications



Series 801
High Speed
Mighty Mouse

“Multiple Access,” multiple hosts are connected to the common medium; and “Collision Detection,” when a host transmits, the protocols can determine whether its transmission has collided with the transmission of another host. If two or more information packets are sent simultaneously, a collision occurs and neither transmission is successful—collision detection instructs the system to retransmit the colliding packets. Legacy Ethernet is half-duplex, meaning information can move in only one direction at a time, and is less-than-ideal for many avionic applications, as fastest-possible communication is not guaranteed. The collision problem occurs in any bus-oriented architecture, such as MIL-STD-1553.

Full-duplex, switched Ethernet eliminates the collision problem by employing links that are point-to-point (not a bus) with a separate twisted pair for transmission and reception. Full-duplex also has the ability to send and receive data at the same time by employing a network of Ethernet switches able to forward incoming packets to their appropriate destinations. Gigabit Ethernet transfers data on four pairs of wires instead of only two pairs under legacy Ethernet forms. Further, transmission coding is enhanced for Gigabit Ethernet so that the standard clock rate of 125 MHz that produces 100 mbps data transfer rates in so-called “Fast Ethernet” is supercharged to 1,000 mbps. Gigabit Ethernet can fit

an order of magnitude more data into the same cable than can Fast Ethernet, but employs the same transmission schemes and frame format as the earlier Ethernet versions.

IEEE 1394

In the early 1990s, Apple Computer and Texas Instruments worked with the Institute of Electrical and Electronics Engineers (IEEE) to establish a very fast serial bus interface standard that supports data transfer rates of up to 400 mbps (in 1394a) and 800 mbps (in 1394b). Products supporting the 1394 standard go under different names, depending on the company. Apple uses the name FireWire, Texas Instrument uses Lynx and Sony uses i.link to describe their 1394 products. A single 1394 port can be used to connect up to 63 external devices. In addition to its high speed, 1394 also supports isochronous data, delivering data at a guaranteed rate. This isochronous feature makes it ideal for devices that need to transfer

high levels of data in real-time, such as video and audio applications. 1394 makes full use of all SCSI (Small Computer System Interface, a parallel interface standard used for attaching peripheral devices to computers).

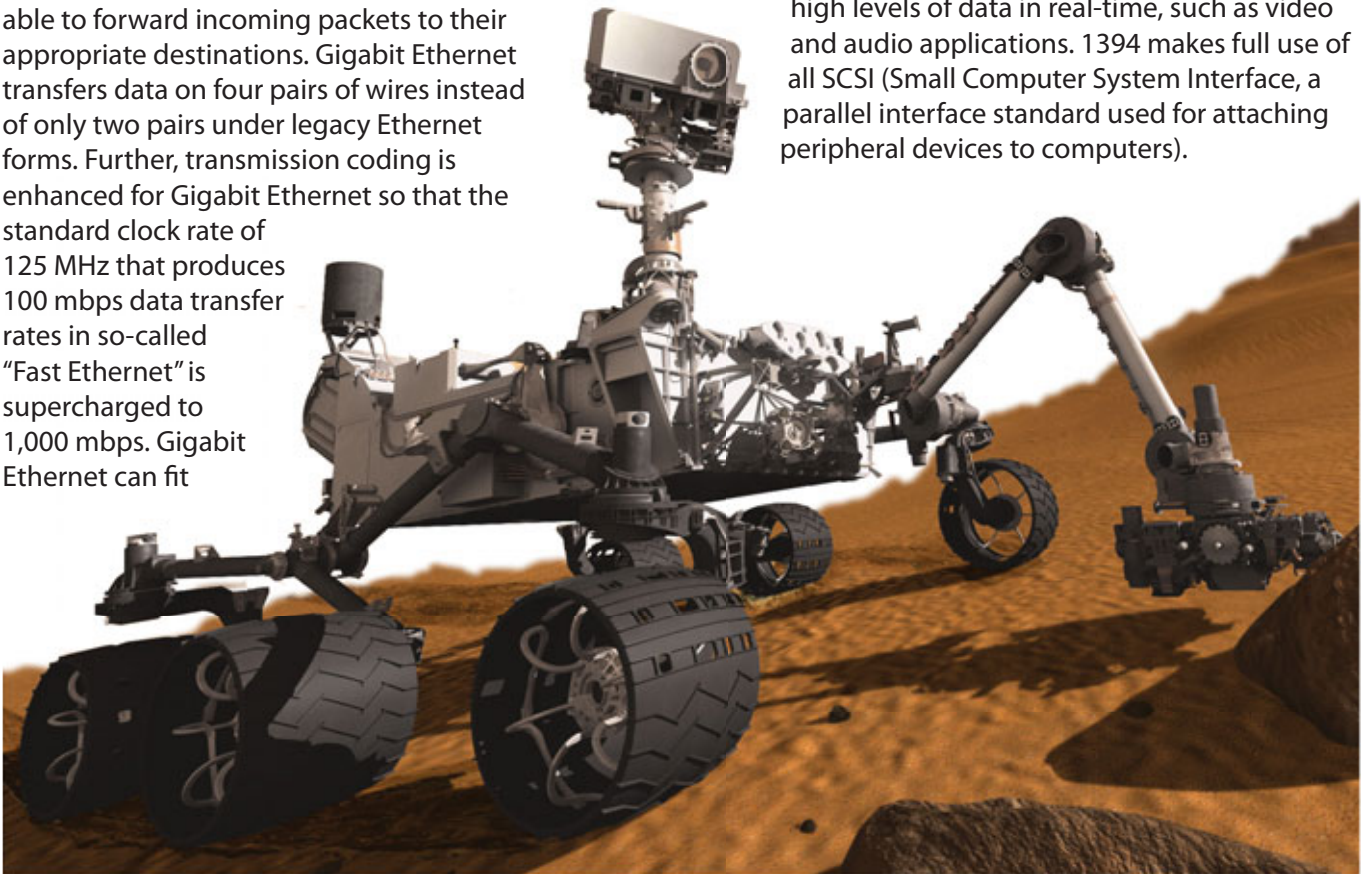

MIL-STD-1553

MIL-STD-1553 defines all aspects of the serial digital multiplex data bus for military vehicles. Multiplexing combines two or more information channels on to a common transmission medium. When compared to older analog point-to-point wire bundles, multiplexing allows for weight reduction, simplicity of system design, standardization and flexibility. The 1553 data bus provides integrated, centralized system control and a standard interface for all interconnected equipment. Devices connect using twisted, shielded pairs of wires to maintain message integrity. All devices in the system are connected to a redundant pair of buses to provide a second path of traffic should one of the buses become damaged. Data rates of 1 megabit per second (mbps) are standard under MIL-STD-1553. MIL-STD-1773 contains the requirements for fiber optic cabling systems as a 1553 bus transmission medium.

SATA

Serial ATA (SATA or Serial Advanced Technology Attachment) is a computer bus interface for connecting host bus adapters to mass storage devices such as hard disk drives and optical drives. Serial ATA was designed to replace the older ATA (AT Attachment) standard (also known as EIDE), offering several advantages over the older parallel ATA (PATA) interface: reduced cable-bulk and cost (7 conductors versus 40), native hot swapping, faster data transfer through higher signalling rates, and more efficient transfer through an optional I/O queuing protocol. SATA is an emerging standard in C4ISR and other forms of battlefield communications and data transmission electronics.



SATA host-adapters and devices communicate via a high-speed serial cable over two pairs of conductors.

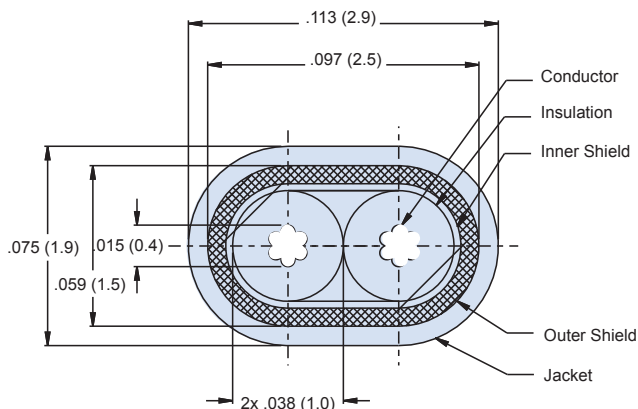

Cross-section of Glenair high-performance series 859-041 100 Ohm differential parallel pair cable. For SATA applications Glenair recommends our 801-045 cordsets with two parallel pairs of the special wire terminated to four #23 AWG contacts.

Series 859-041 Cable Construction Details

Conductor	28 AWG Silver Plated High Strength Copper Alloy
Insulation	Extruded Foamed Fluoropolymer Color: Blue and White
Inner Shield	Aluminum/Polyester Tape, 100% Coverage
Outer Shield	Round Silver Plated Copper Braid, 90% Coverage
Jacket	Extruded FEP Color: Transparent Blue

Series 859-041 Cable Properties

Impedance	100 ± 10 Ohms
Capacitance	12.0 pF/Ft (Nom)
V.O.P.	80%
Attenuation	0.25 dB/m @ 100 MHz 0.75 dB/m @ 500 MHz 1.25 dB/m @ 1000 MHz
Temperature Rating	150° C



High-Performance, High-Speed Differential Technologies Available Now From Glenair

High Speed Series 80 Mighty Mouse Connectors with DuPont™ Teflon® PFA Insulators



The Series 80 *High Speed* Mighty Mouse is Glenair's latest entry in our world of *high-speed* interconnect solutions. The connector is equipped with special PFA (Teflon) insulators and is optimized for use with high-speed differential wire such as our 859-041 series cable. Three insert arrangements are offered with 4, 7 and 10 size #23 contacts. The high-density, small form factor connector is suited for applications where traditional military circular connectors are too large or too heavy, and where the demands for high bandwidth, balanced impedance performance are at their highest. Other Glenair *High Speed* Solutions include:

High-Bandwidth Fiber Optic Connectors, Cables, and Termini

From our QPL MIL-PRF-28876 fiber optic connectors to our MIL-DTL-38999 type solutions, Glenair produces advanced performance fiber optic interconnection systems for every military and commercial standard. Fiber optic connectors, termini and cabling deliver secure high speed data in applications that require superior insertion loss and high data throughput. Fiber optic interconnect systems offer exponentially larger bandwidth compared to standard electrical cabling. Glenair manufactures a solution for every branch of the military and every mission-critical commercial application. Series #16 AWG Mighty Mouse fiber optic solutions are also now available.



High-Performance Shielded Contact Connectors

High-speed differential impedance contacts, such as those used in advanced digital communications applications, are another key specialty at Glenair. Our Twinax and Quadrax contacts are exactly engineered and manufactured using the best available materials and manufacturing processes. Conductive elements are gold-plated copper alloy. Dielectrics are high performance fluorocarbon. Most Glenair cylindrical connectors, including our D38999 type, can accommodate shielded contacts that deliver balanced impedance performance for application frequencies above 1GHz..

Field-Ready, Integrated RJ-45 and USB Connectors

Glenair integrates commercial connection devices that traditionally deliver datalinks for high-speed protocols into standard MS type connector shells. We offer rugged field-ready circular connectors that enclose single and double RJ-45 or USB connectors. Users of these standard products need not worry about damaging delicate high bandwidth connections in harsh conditions when these connectors are deployed in place of standard, non-protected solutions. The MIL-DTL-5015 or MIL-DTL-26482 type connector shells provide impact resistance, ingress protection and positive coupling.

