

Standard Band 600-052 and Precoiled Standard Band 600-052-1

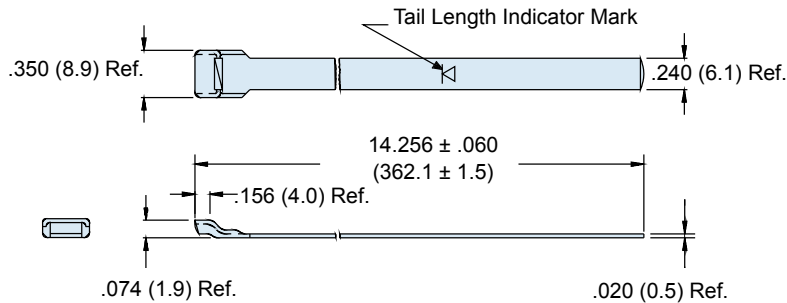

The 600-052 Standard Band is precision constructed of 300 Series SST/Passivate and designed for use with the 600-058 Hand Banding Tool or the 600-067 Pneumatic Banding Tool. Double-wrapped bands will accommodate diameters up to approximately 1.8 inches (45.7). Bands may be ordered flat (600-052) or precoiled (600-052-1). Bands come bagged and tagged in quantities from 1 to 100.

Reference: **BAND-IT®** Part Number **A10086**

Extended-Length Standard Band 600-090 and Precoiled Extended-Length Standard Band 600-090-1

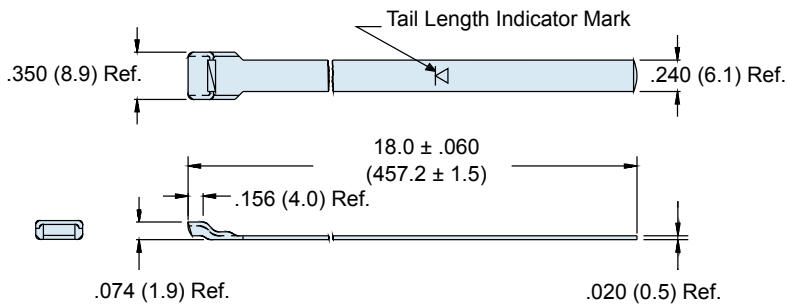

The 600-090 Extended Length Standard Band is precision constructed of 300 Series SST/Passivate, and designed for use with the 600-058 Hand Banding Tool or the 600-067 Pneumatic Banding Tool. Double-wrapped bands will accommodate diameters up to approximately 2.5 inches (63.5). Bands may be ordered flat (600-090), or precoiled (600-090-1). Bands come bagged and tagged in quantities from 1 to 100.

Reference: **BAND-IT®** Part Number **A11086**

Micro-Band 600-057 Precoiled Micro-Band 600-057-1

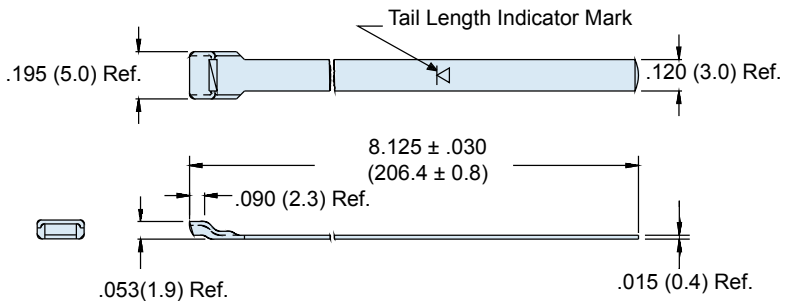

The 600-057 Micro Band is precision constructed of 300 Series SST/Passivate, and designed for use with the 600-061 Hand Banding Tool or the 600-068 Pneumatic Banding Tool. Double-wrapped bands will accommodate diameters up to approximately .88 inches (22.4). Bands may be ordered flat (600-057), or precoiled (600-057-1). Bands come bagged and tagged in quantities from 1 to 100.

Reference: **BAND-IT®** Part Number **A31186**

Extended Length Micro-Band 600-083 Precoiled Micro-Band 600-083-1

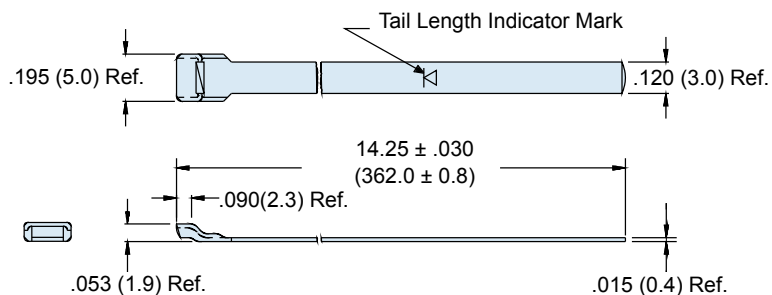

The 600-083 Extended Length Micro-Band is precision constructed of 300 Series SST/Passivate, and designed for use with the 600-061 Hand Banding Tool or the 600-068 Pneumatic Banding Tool. Double-wrapped bands will accommodate diameters up to approximately 1.88 inches (47.8). Bands may be ordered flat (600-083), or precoiled (600-083-1). Bands come bagged and tagged in quantities from 1 to 100.

Reference: **BAND-IT®** Part Number **A31089**.

Metric dimensions (mm) are indicated in parentheses. Consult factory for diameters above 2.5 inches (63.5).