

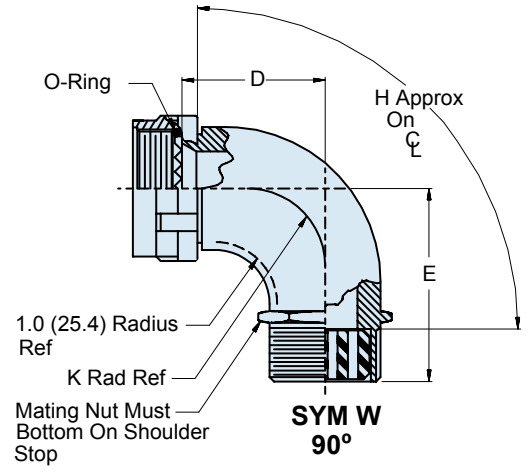

377-014 Composite Thermoplastic Backshell for Fiber Optic MIL-DTL-38999 Series III & IV Connectors

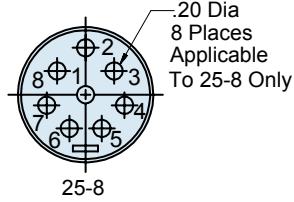
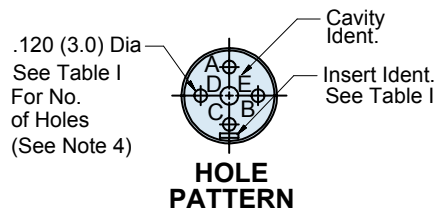
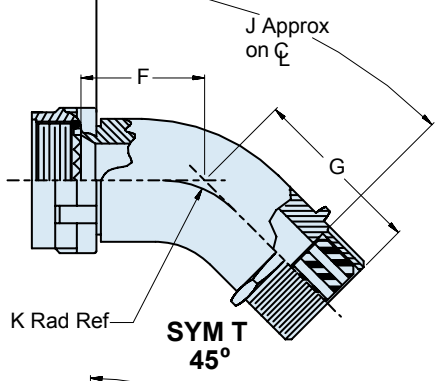
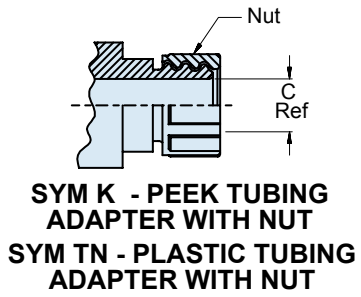
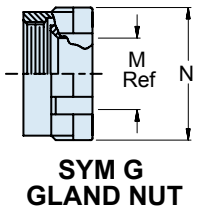
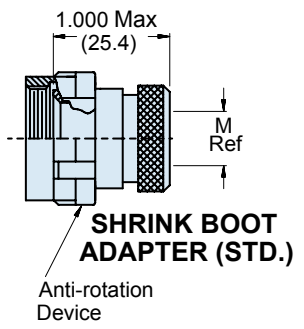
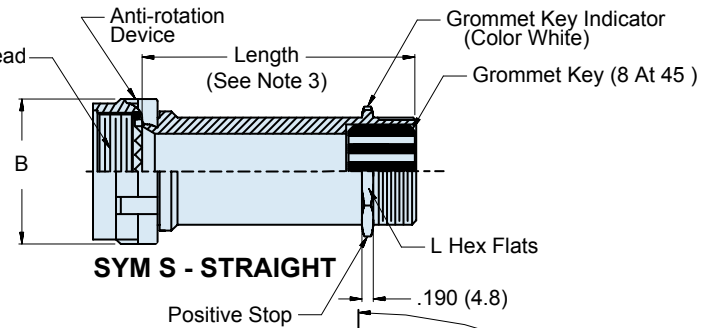
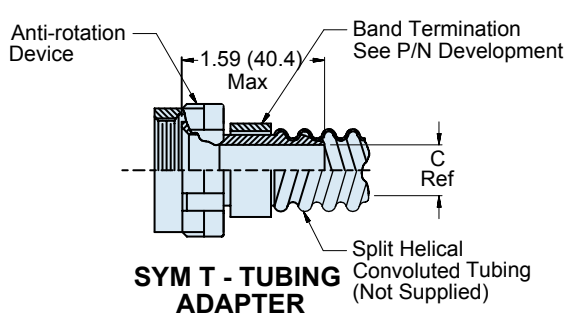
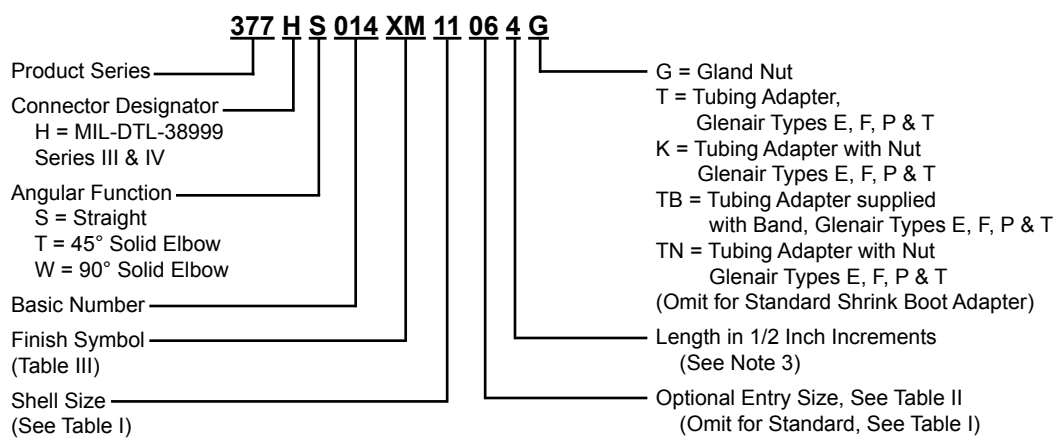

© 2006 Glenair, Inc. CAGE Code 06324 Printed in U.S.A.

377-014
Composite Thermoplastic Backshell
for Fiber Optic MIL-DTL-38999 Series III & IV Connectors



TABLE I: SHELL SIZE

Shell Size	A Thread ISO Metric	B Max	Standard Conduit Size	D Max	E Max	F Max	G Max	H Approx.	Insert Ident	No. of Holes
11	M15 x 1 - 6H	1.000 (25.4)	3/8	1.780 (45.2)	1.930 (49.0)	1.330 (33.8)	1.560 (39.6)	2.230 (56.6)	11-2	2
13	M18 x 1 - 6H	1.120 (28.4)	7/16	1.840 (46.7)	1.980 (50.3)	1.390 (35.3)	1.620 (41.1)	2.280 (57.9)	13-4	4
15	M22 x 1 - 6H	1.250 (31.8)	1/2	1.900 (48.3)	2.080 (52.8)	1.450 (36.8)	1.680 (42.7)	2.450 (62.2)	15-5	5
17	M25 x 1 - 6H	1.380 (35.1)	5/8	1.970 (50.0)	2.140 (54.4)	1.510 (38.4)	1.740 (44.2)	2.470 (62.7)	17-8	8
19	M28 x 1 - 6H	1.500 (38.1)	3/4	2.110 (53.6)	2.180 (55.4)	1.540 (39.1)	1.770 (45.0)	2.540 (64.5)	19-11	11
21	M31 x 1 - 6H	1.620 (41.0)	7/8	2.070 (52.6)	2.250 (57.2)	1.160 (40.9)	1.840 (46.7)	2.640 (67.1)	21-16	16
23	M34 x 1 - 6H	1.750 (44.5)	1	2.140 (54.4)	2.310 (58.7)	1.670 (42.4)	1.890 (48.0)	2.760 (70.1)	23-21	21
25	M37 x 1 - 6H	1.880 (47.8)	1	2.190 (55.6)	2.190 (55.6)	1.730 (43.9)	1.960 (49.8)	2.840 (72.1)	25-29	29
25-8	M37 x 1 - 6H	1.880 (47.8)	1 - 1/4	2.190 (55.6)	2.190 (55.6)	1.730 (43.9)	1.960 (49.8)	2.840 (72.1)	25-8	8
25-37	M37 x 1 - 6H	1.880 (47.8)	1 - 1/4	2.190 (55.6)	2.190 (55.6)	1.730 (43.9)	1.960 (49.8)	2.840 (72.1)	25-37	37

TABLE I: SHELL SIZE (CONTINUED)

Shell Size	A Thread ISO Metric	B Max	Standard Conduit Size	J Approx.	K Ref	L Flats	M Ref	N Max	Insert Ident	No. of Holes
11	M15 x 1 - 6H	1.000 (25.4)	3/8	2.090 (53.1)	1.200 (30.5)	.938 (23.8)	.320 (81.3)	1.380 (35.1)	11-2	2
13	M18 x 1 - 6H	1.120 (28.4)	7/16	2.210 (56.1)	1.260 (32.0)	.938 (23.8)	.540 (13.7)	1.380 (35.1)	13-4	4
15	M22 x 1 - 6H	1.250 (31.8)	1/2	2.330 (59.2)	1.320 (33.5)	.938 (23.8)	.540 (13.7)	1.380 (35.1)	15-5	5
17	M25 x 1 - 6H	1.380 (35.1)	5/8	2.440 (62.0)	1.380 (35.1)	1.250 (31.8)	.760 (19.3)	1.560 (39.6)	17-8	8
19	M28 x 1 - 6H	1.500 (38.1)	3/4	2.500 (63.5)	1.430 (36.3)	1.250 (31.8)	.760 (19.3)	1.560 (39.6)	19-11	11
21	M31 x 1 - 6H	1.620 (41.0)	7/8	2.640 (67.1)	1.490 (37.8)	1.500 (38.1)	1.000 (25.4)	1.810 (46.0)	21-16	16
23	M34 x 1 - 6H	1.750 (44.5)	1	2.750 (69.9)	1.550 (39.4)	1.500 (38.1)	1.000 (25.4)	1.810 (46.0)	23-21	21
25	M37 x 1 - 6H	1.880 (47.8)	1	2.870 (72.9)	1.620 (41.1)	1.812 (46.0)	1.270 (32.3)	2.120 (53.8)	25-29	29
25-8	M37 x 1 - 6H	1.880 (47.8)	1 - 1/4	2.870 (72.9)	1.620 (41.1)	1.812 (46.0)	1.270 (32.3)	2.120 (53.8)	25-8	8
25-37	M37 x 1 - 6H	1.880 (47.8)	1 - 1/4	2.870 (72.9)	1.620 (41.1)	1.812 (46.0)	1.270 (32.3)	2.120 (53.8)	25-37	37

TABLE III: FINISH

SYM	MATERIAL	FINISH
-	Composite	No Plating
XB	Composite	No Plating, Black Color
XM	Composite	Electroless Nickel - Backshell, No Plating on Coupling Nut or Rear Entry Components - Amber Color
XW	Composite	Cadmium Plate/Olive Drab over Electroless Nickel Backshell No Plating on Coupling Nut or Rear Components - Amber Color

TABLE II: ENTRY SIZE

Entry Size	C Ref	Optional Conduit Size Ref
03	.219 (5.6)	9/32
04	.236 (6.0)	5/32
05	.250 (6.4)	3/8
06	.338 (8.6)	7/16
07	.394 (10.0)	1/2
08	.519 (13.2)	5/8
10	.644 (16.4)	3/4
11	.644 (16.4)	3/4
13	.772 (19.6)	7/8
15	.894 (22.7)	1
17	1.102 (28.0)	1 - 1/4

APPLICATION NOTES

1. Assembly identified with manufacturer's name and P/N, space permitting.
2. Glenair 600 series Backshell assembly tools are recommended for assembly and installation.
3. Standard min. order length 1.5 inch, consult factory for shorter lengths.
4. For sealing plugs see Glenair drawing 687-142.
5. Material:
 Adapters, Elbows, Ferrules, Coupling Nut, Nut: Hi- Grade Engineering thermoplastic/ see Table III
 Grommet, O-Ring: Fluorosilicone/ N.A.
 Anti-Rotation Device: Corrosion Resistant Material/ N.A.
6. Metric dimensions (mm) are indicated in parentheses.