

180-122
**GHD • Glenair High Density
 Fiber Optic Connection System
 Panel Cut-Out and Mounting Holes**

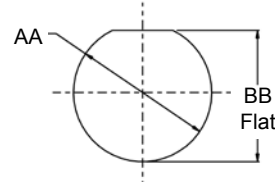
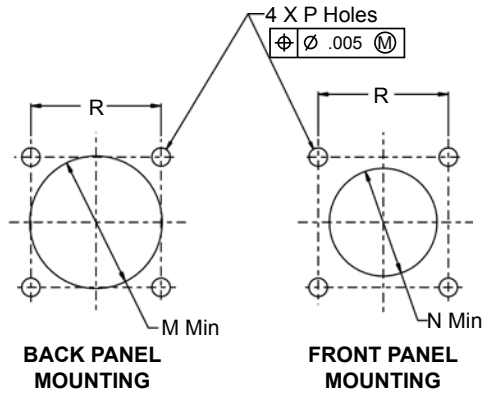

**RECOMMENDED
 PANEL CUT-OUT**

(See Table V)

**RECOMMENDED MOUNTING HOLES
 FOR WALL MOUNT RECEPTACLES**
 (See Table III)

**TABLE III: MOUNTING HOLES
 FOR WALL-MOUNT RECEPTACLES**

Shell Size Code	Shell Size	M Dia Min	N Dia Min	P Holes	R BSC
B	11	.796 (20.2)	.625 (15.9)	.133 (3.4) .123 (3.1)	.812 (20.6)
C	13	.922 (23.4)	.750 (19.1)	.133 (3.4) .123 (3.1)	.906 (23.0)
D	15	1.047 (26.6)	.906 (23.0)	.133 (3.4) .123 (3.1)	.969 (24.6)
E	17	1.219 (31.0)	1.016 (25.8)	.133 (3.4) .123 (3.1)	1.062 (27.0)
F	19	1.297 (32.9)	1.141 (29.0)	.133 (3.4) .123 (3.1)	1.156 (29.4)
G	21	1.422 (36.1)	1.266 (32.2)	.133 (3.4) .123 (3.1)	1.250 (31.8)
H	23	1.547 (39.3)	1.375 (34.9)	.159 (4.0) .149 (3.8)	1.375 (34.9)
J	25	1.672 (42.5)	1.484 (37.7)	.155 (3.9) .145 (3.7)	1.500 (38.1)

TABLE V: PANEL CUT-OUT

Shell Size Code	Shell Size	AA Dia Min	BB Flat
B	11	.835 (21.2) .825 (20.9)	.771 (19.6) .761 (19.3)
C	13	1.020 (25.9) 1.010 (25.7)	.955 (24.3) .945 (24.0)
D	15	1.145 (29.1) 1.135 (28.8)	1.085 (27.6) 1.075 (27.3)
E	17	1.270 (32.3) 1.260 (32.0)	1.210 (30.7) 1.200 (30.5)
F	19	1.395 (35.4) 1.385 (35.2)	1.335 (33.9) 1.325 (33.7)
G	21	1.520 (38.6) 1.510 (38.4)	1.460 (37.1) 1.450 (36.8)
H	23	1.645 (41.8) 1.635 (41.5)	1.585 (40.3) 1.575 (40.0)
J	25	1.770 (45.0) 1.760 (44.7)	1.710 (43.4) 1.700 (43.2)