

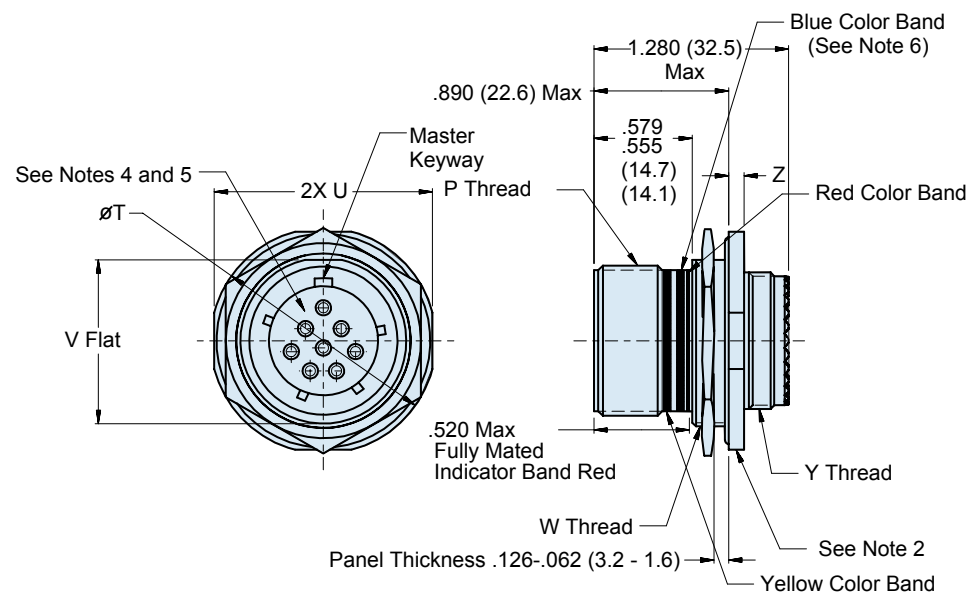

180-091 (08 Jam Nut Mount)
Advanced Fiber Optic Receptacle Connector
MIL-DTL-38999 Series III Style

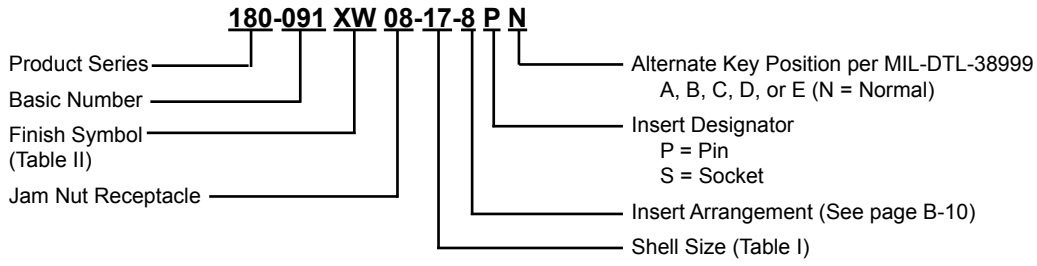

08 - JAM NUT MOUNT RECEPTACLE

APPLICATION NOTES

1. Material/ Finishes:
Shells, Jam Nut - See Table II (Composite Jam Nut No Plating Required).
Insulators- High Grade Rigid Dielectric/ N.A
Seals- Fluorosilicone/ N.A.
2. Assembly to be identified with Glenair's name, part number and date code space permitting.
3. Modified major diameter 31.80-31.95 (1.252-1.257).
4. Insert arrangement in accordance with MIL-STD-1560, See Page B-10.
5. Insert arrangement shown is for reference only.
6. Blue Color Band indicates rear release retention system.
7. For appropriate Glenair Terminus part numbers see Glenair Drawing 181-001 and 181-002.
8. Metric dimensions (mm) are in parentheses.

**180-091 (08 Jam Nut Mount)
Advanced Fiber Optic Receptacle Connector
MIL-DTL-38999 Series III Style**



TABLE I: SHELL SIZE

Shell Size Code	Shell Size	P Thread	T Dia	U	V	W Thread	Y Thread	Z
B	11	.7500-.1P-.3L-TS-2A	1.386 (35.2) 1.362 (34.6)	1.268 (32.2) 1.236 (31.4)	.755 (19.2) .745 (18.9)	M20 x 1.0-6g 0.100R	M15 x 1.0-6g 0.100R	.121 (3.1) .083 (2.1)
C	13	.8750-.1P-.3L-TS-2A	1.512 (38.4) 1.488 (37.8)	1.390 (35.3) 1.358 (34.5)	.942 (23.9) .932 (23.7)	M25 x 1.0-6g 0.100R	M18 x 1.0-6g 0.100R	.121 (3.1) .083 (2.1)
D	15	1.0000-.1P-.3L-TS-2A	1.638 (41.6) 1.614 (41.0)	1.516 (38.5) 1.484 (37.7)	1.066 (27.1) 1.056 (26.8)	M28 x 1.0-6g 0.100R	M22 x 1.0-6g 0.100R	.121 (3.1) .083 (2.1)
E	17	1.1875-.1P-.3L-TS-2A	1.764 (44.8) 1.740 (44.2)	1.642 (41.7) 1.610 (40.9)	1.191 (30.3) 1.181 (30.0)	M32 x 1.0-6g 0.100R*	M25 x 1.0-6g 0.100R	.121 (3.1) .083 (2.1)
F	19	1.2500-.1P-.3L-TS-2A	1.949 (49.5) 1.925 (48.9)	1.827 (46.4) 1.795 (45.6)	1.316 (33.4) 1.306 (33.2)	M35 x 1.0-6g 0.100R	M28 x 1.0-6g 0.100R	.154 (3.9) .114 (2.9)
G	21	1.3750-.1P-.3L-TS-2A	2.075 (52.7) 2.051 (52.1)	1.953 (49.6) 1.921 (48.8)	1.441 (36.6) 1.431 (36.3)	M38 x 1.0-6g 0.100R	M31 x 1.0-6g 0.100R	.154 (3.9) .114 (2.9)
H	23	1.5000-.1P-.3L-TS-2A	2.201 (55.9) 2.177 (55.3)	2.079 (52.8) 2.047 (52.0)	1.566 (39.8) 1.556 (39.5)	M41 x 1.0-6g 0.100R	M34 x 1.0-6g 0.100R	.154 (3.9) .114 (2.9)
J	25	1.6250-.1P-.3L-TS-2A	2.323 (59.0) 2.299 (58.4)	2.205 (56.0) 2.173 (55.2)	1.691 (43.0) 1.681 (42.7)	M44 x 1.0-6g 0.100R	M37 x 1.0-6g 0.100R	.154 (3.9) .114 (2.9)

*See Note 3

TABLE II: FINISH

SYM	MATERIAL	FINISH
M	Aluminum	Electroless Nickel
NF		Cadmium O.D. Over Electroless Nickel
ZNU		Black Chromate over Zinc-Nickel over Electroless Nickel
XMS	Composite	Electroless Copper
XM		Electroless Nickel
XW		Cadmium O.D. Over Electroless Nickel
MS	Stainless Steel	Electroless Nickel
Z1		Passivate
ZL		Electro-Deposited Nickel