

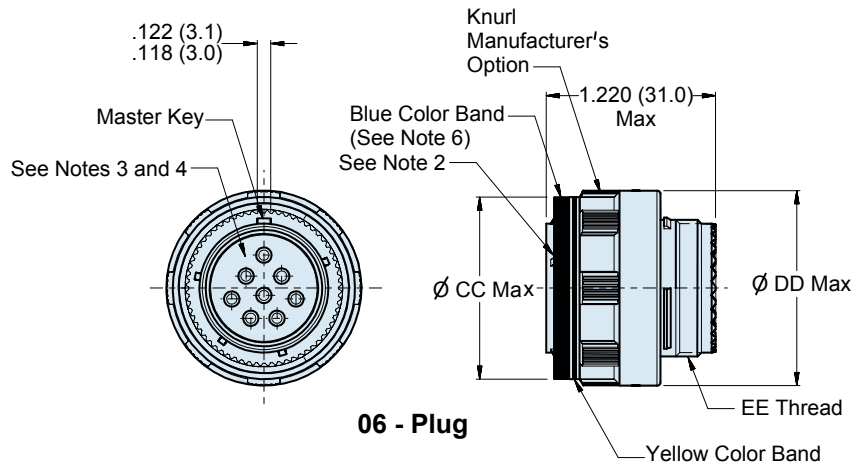

180-091 (06 Plug) Advanced Fiber Optic Plug Connector MIL-DTL-38999 Series III Style

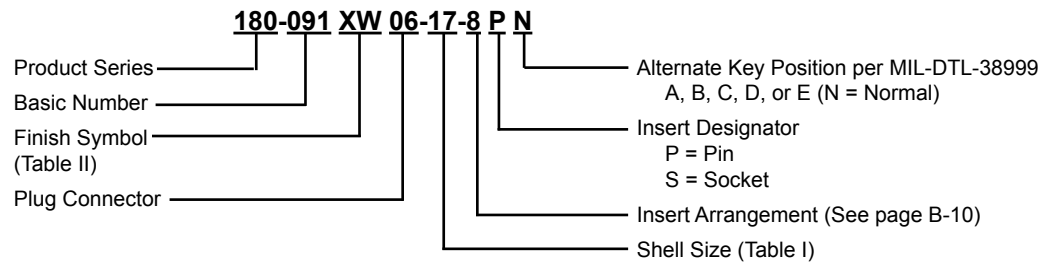

APPLICATION NOTES

- | | |
|--|--|
| <ol style="list-style-type: none"> 1. Material/ Finishes:
Barrel, Coupling Nut - See Table II
(Composite Coupling Nut - No Plating Required).
Insulators- High Grade Rigid Dielectric/ N.A
Seals- Fluorosilicone/ N.A. 2. Assembly to be identified with Glenair's name, part number and date code space permitting. | <ol style="list-style-type: none"> 3. Insert arrangement in accordance with MIL-STD-1560, See Page B-10. 4. Insert arrangement shown is for reference only. 5. Blue Color Band indicates rear release retention system. 6. For appropriate Glenair Terminus part numbers see Glenair Drawing 181-001 and 181-002. 7. Metric Dimensions (mm) are indicated in parentheses. |
|--|--|

180-091 (06 Plug)
Advanced Fiber Optic Plug Connector
MIL-DTL-38999 Series III Style



TABLE I: SHELL SIZE

Shell Size Code	Shell Size	CC Max Dia	DD Max Dia	EE Thread
B	11	.929 (23.6)	.984 (25.0)	M15 x 1.0-6g 0.100R
C	13	1.110 (28.2)	1.157 (29.4)	M18 x 1.0-6g 0.100R
D	15	1.232 (31.3)	1.280 (32.5)	M22 x 1.0-6g 0.100R
E	17	1.358 (34.5)	1.406 (35.7)	M25 x 1.0-6g 0.100R
F	19	1.469 (37.3)	1.516 (38.5)	M28 x 1.0-6g 0.100R
G	21	1.594 (40.5)	1.642 (41.7)	M31 x 1.0-6g 0.100R
H	23	1.720 (43.7)	1.768 (44.9)	M34 x 1.0-6g 0.100R
J	25	1.843 (46.8)	1.890 (48.0)	M37 x 1.0-6g 0.100R

TABLE II: FINISH

SYM	MATERIAL	FINISH
M	Aluminum	Electroless Nickel
NF		Cadmium O.D. Over Electroless Nickel
ZNU		Black Chromate over Zinc-Nickel over Electroless Nickel
XMS	Composite	Electroless Copper
XM		Electroless Nickel
XW		Cadmium O.D. Over Electroless Nickel
MS	Stainless Steel	Electroless Nickel
Z1		Passivate
ZL		Electro-Deposited Nickel