

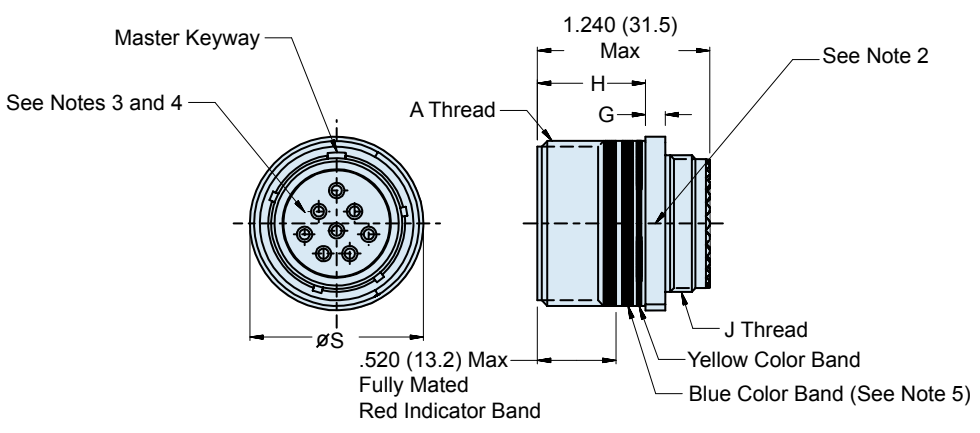

180-091 (05 In-Line)
Advanced Fiber Optic Receptacle Connector
MIL-DTL-38999 Series III Style

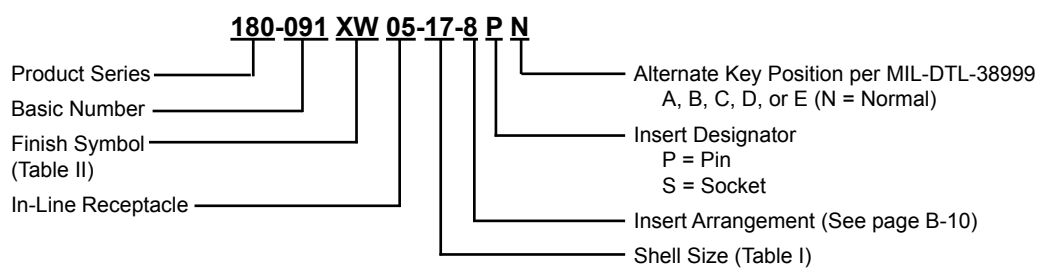

05 - IN-LINE RECEPTACLE

APPLICATION NOTES

- Material/ Finishes:
Shells - See Table II
Insulator- High Grade Rigid Dielectric/ N.A.
Seals- Fluorosilicone/ N.A.
- Assembly to be identified with Glenair's name, part number and date code space permitting.
- Insert arrangement in accordance with MIL-STD-1560, See Page B-10.
- Insert arrangement shown is for reference only.
- Blue Color Band indicates rear release retention system.
- For appropriate Glenair Terminus part numbers see Glenair Drawing 181-001 and 181-002.
- Metric Dimensions (mm) are indicated in parentheses.

**180-091 (05 In-Line)
Advanced Fiber Optic Receptacle Connector
MIL-DTL-38999 Series III Style**



TABLE I: SHELL SIZE

Shell Size Code	Shell Size	A Thread	G	H	S Dia	J Thread
B	11	.7500-.1P-.3L-TS-2A	.144 (3.7) .083 (2.1)	.823 (20.9) .768 (19.5)	.840 (21.3)	M15 x 1.0-6g 0.100R
C	13	.8750-.1P-.3L-TS-2A	.144 (3.7) .083 (2.1)	.823 (20.9) .768 (19.5)	.963 (24.5)	M18 x 1.0-6g 0.100R
D	15	1.0000-.1P-.3L-TS-2A	.144 (3.7) .083 (2.1)	.823 (20.9) .768 (19.5)	1.090 (27.7)	M22 x 1.0-6g 0.100R
E	17	1.1875-.1P-.3L-TS-2A	.144 (3.7) .083 (2.1)	.823 (20.9) .768 (19.5)	1.275 (32.4)	M25 x 1.0-6g 0.100R
F	19	1.2500-.1P-.3L-TS-2A	.144 (3.7) .083 (2.1)	.823 (20.9) .768 (19.5)	1.337 (34.0)	M28 x 1.0-6g 0.100R
G	21	1.3750-.1P-.3L-TS-2A	.171 (65.2) .083 (39.8)	.791 (20.0) .736 (18.7)	1.463 (37.2)	M31 x 1.0-6g 0.100R
H	23	1.5000-.1P-.3L-TS-2A	.171 (65.2) .083 (39.8)	.791 (20.0) .736 (18.7)	1.587 (40.3)	M34 x 1.0-6g 0.100R
J	25	1.6250-.1P-.3L-TS-2A	.171 (65.2) .083 (39.8)	.791 (20.0) .736 (18.7)	1.713 (43.5)	M37 x 1.0-6g 0.100R

TABLE II: MATERIAL AND FINISH

SYM	MATERIAL	FINISH DESCRIPTION
M*	Aluminum	Electroless Nickel
MT		Nickel - PTFE
NF		Cadmium, Olive Drab
ZNU		Zinc-Nickel, Black
XM*	Composite	Electroless Nickel
XMT		Nickel - PTFE
XO		No Plating
XW		Cadmium, Olive Drab
XZN		Zinc-Nickel, Black
MS	Stainless Steel	Electroless Nickel
ZL*		Electro-Deposited Nickel
Z1*		Passivate

*RoHS Compliant