

Swivel Design, Self-Locking Couplings, Environmental Sealing—Truly the *FIRST* and Last Conduit System You'll Ever Need

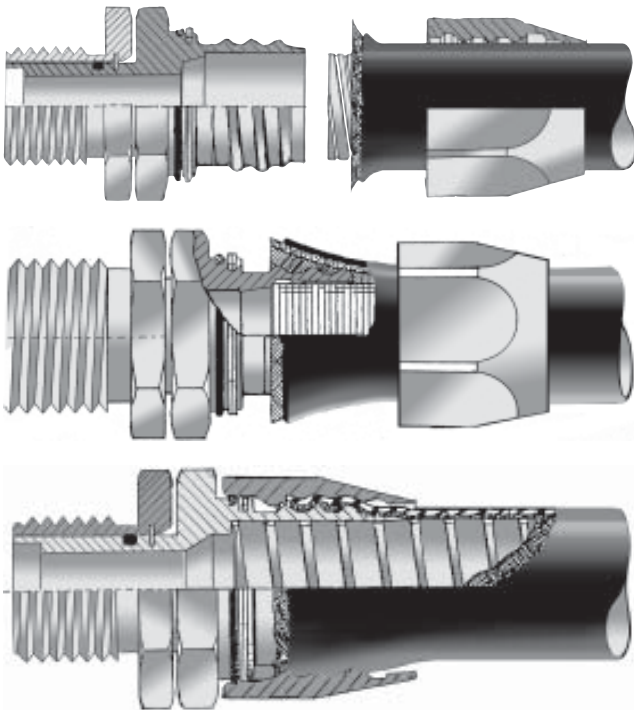

PRODUCT FACTS

- Broad Spectrum RFI/EMI/EMP Shielding
- Interchangeability with Entraco*
- Reduced Radar Cross section
- Easy Installation and Repair
- Low-Smoke Zero Halogen Jacketing
- 360° Grounding Swivel Design
- Self-Coupling Adapters with Wave-Form Anti-Decoupling Springs

The Glenair Field Installable and Repairable Shipboard Termination (*FIRST*) Conduit System consists of easily installed, two-piece conduit fittings and Glenair's Series 75 metal core conduit (750-145 and 750-147).

The *FIRST* System provides optimized shielding, extreme environment sealing, and corrosion protection. The self-locking coupling system, with its front swivel and rear coupling nut wave-form spring, ensures continued protection

even under conditions of severe shock, vibration and cable torque. No other system on the market is easier to install or repair, and no special tools are required. Installation time is greatly reduced, and service life is increased.

Body configurations are available in straight, 45° and 90°. The selection of end-fittings and adapters support all military standard connectors, bulkhead feed-throughs, branching hardware, pipe threads and stuffing tubes.

* ENTRACO is a trademark of Icore Int'l, Inc., a part of Smiths Industries