

# TG70 Strap Wrench

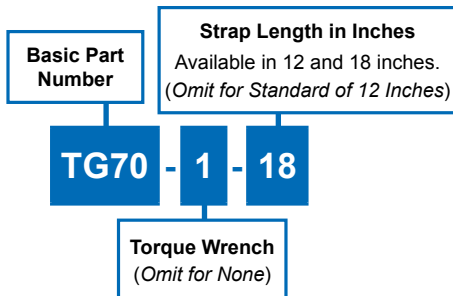
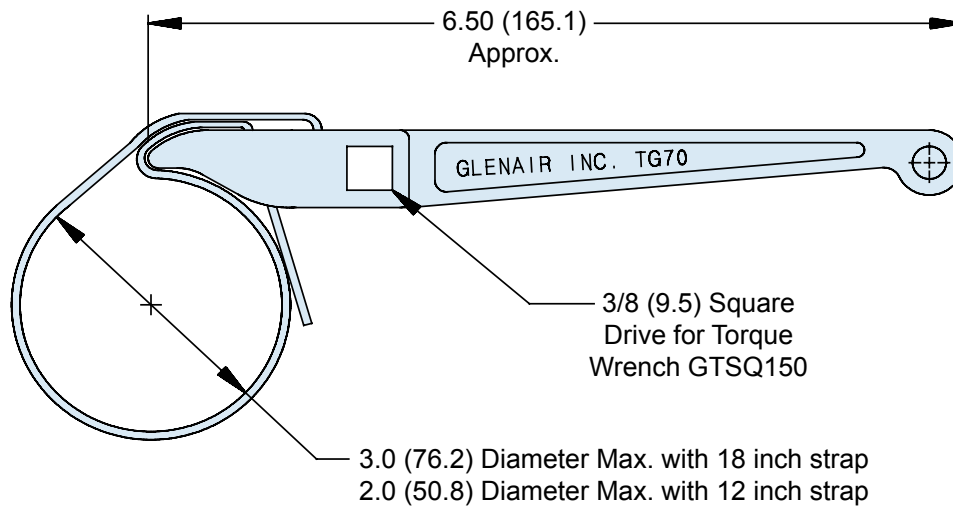

VARIANCE CHART TG-70 Strap Wrench Used with Glenair Torque Wrenches		
Accessory Shell Size	Recommended Installation Torque	
	Light/Medium Duty ± 5 Inch Pounds	
	TG70 Torque	Part Torque
08/09	28	35
10/11	28	35
12/13	30	40
14/15	30	40
16/17	30	40
18/19	30	40
20/21	75	80
22/23	75	80
24/25	75	80
28	75	80
32	75	80
36	75	80

\* TG70 Not Recommended For Values of 120 Inch Lbs. or Greater.

**VARIANCE CHART NOTES:**

1. Recommended installation torque is approximately 80% of AS85049 accessory thread strength values.

**APPLICATION NOTES**

1. Metric dimensions (mm) are in parentheses and are for reference only.
2. These wrenches are made of the following materials:  
Wrench Handle - Aluminum Alloy/Nickel Plate  
Wedge - Stainless Steel/Passivated  
Strap - Impregnated Fabric
3. Replacement straps are available. Specify part number G70515 for 12 inch strap or part number G70515-18 for 18 inch strap.
4. Recommended for 440-087 coupler, 360, 370, 380 and 390 series rear clamps. Consult factory for torque values.
5. **Do not use on hex-style composite coupling nuts.**