

A

Series 370 Environmental Backshell Assembly Instructions

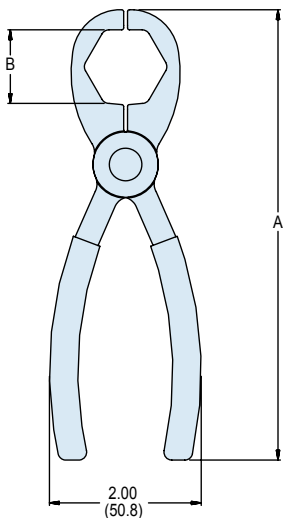

(4) 600-157
Stainless Steel Composite
Hex Coupling Wrench

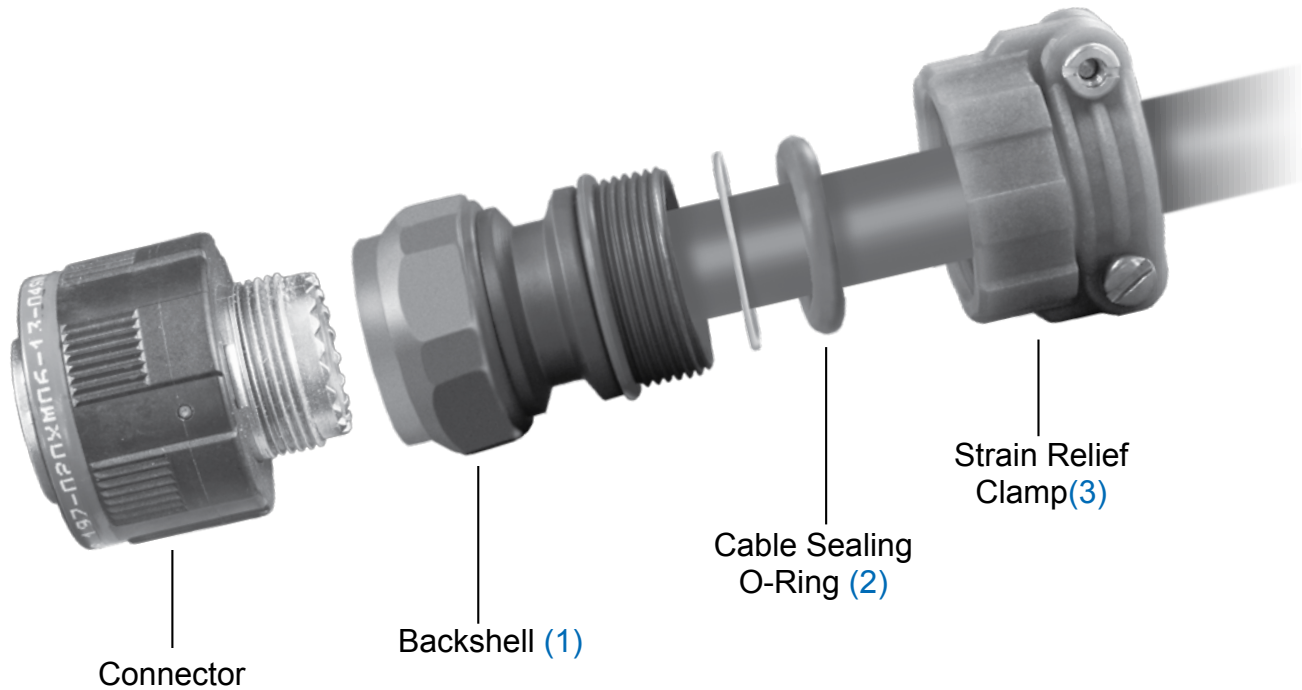
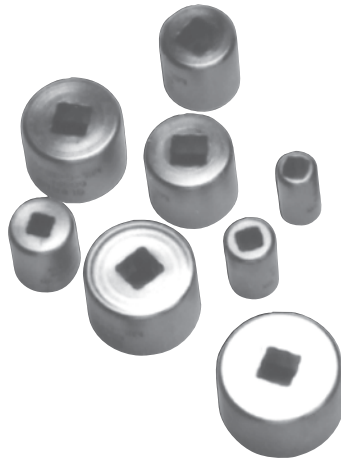

(5) Plug and Receptacle
Holding Tools
for 1/4" and 3/8" Socket



(6) 600-161
Hand Held Digital
Torque Wrench

COMPOSITE COUPLING TORQUE VALUES	
Shell Size Reference	Composite Torque (Inch-Pounds)
08/09	35
10/11	35
12/13	40
14/15	40
16/17	40
18/19	40
20/21	80
22/23	80
24/25	80
28	120
32	120
36	120

The following suggested procedure serves as a guide for proper assembly and installation of straight Glenair Series 370 Cable Sealing Backshells for use with jacketed cables. It is recommended that trial samples of appropriate cables be used to determine proper trim dimensions of the cable jacket and individual conductors.

NOTE: As with any electrical connector assembly procedure, be sure to use the proper tools. For convenient reliable assembly of the connector and backshell, it is suggested that Glenair's connector holding tools, strap wrenches and connector pliers be used.

1. Temporarily assemble backshell (1) to connector.
2. Remove the strain relief clamp (3) and cable sealing o-ring (2) from the backshell and stage them in the order shown up the cable for installation after wires are terminated to the connector contacts.
3. Insert cable into backshell (1) and bottom against connector. Hold cable in position and mark cable jacket at rear end of backshell.
4. Remove backshell from connector and place on cable with components from step two above.
5. Trim cable jacket at a point 3/4 inch toward connector from mark made in step two above.
6. Prepare and terminate wires in accordance with established practices.
7. Thread backshell (1) onto the connector and tighten securely. Glenair recommends the use of the appropriate sized series 600-157 composite hex coupling wrench (4) to prevent damage to the composite backshell coupling nut. For added convenience in assembly, an appropriately sized series 600-005 connector holding tool (5) is recommended, as well as Glenair digital torque wrench (6).
8. Slide washer (if supplied) and O-ring (2) on to backshell and tighten strain relief clamp (3) firmly in place
9. If provided, tighten saddle bar clamps until they bottom against saddle clamp ears (see saddle clamp assembly procedure).