

600-065 Calibration Kit For All Banding Tools

The 600-065 Calibration Kit includes the (1) 600-065-3 Calibration Device, (2) Fifty 600-065-2 Micro Test Bands, (3) Fifty 600-065-1 Standard Test Bands, (4) 600-055 Calibration Key, and the (5) 600-065-4, (6) 600-065-5 and (7) 600-065-6 Mounting Bracket Kits. Range of the Calibration Device is 60 to 170 lbs, and accuracy is calibrated to ± 1 lb. at factory. Dimensions: 6.65 in. x 2.47 in. x 2.83 in. (168.9 x 62.7 x 71.9mm). Weight: 2.10 lbs. (1.0Kg).

Reference: *BAND-IT*[®] part number A50099.

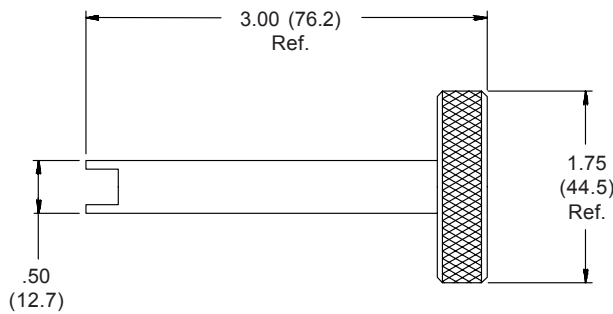

600-055 Calibration Key

The 600-055 Calibration Key is designed for use with the 600-061 and 600-058 Hand Banding Tools. Material is black anodized aluminum alloy. One full turn clockwise will advance the tension range by 25 lbs., and a counter-clockwise turn will decrease tension by the same amount.

Reference: *BAND-IT*[®] part number A44699.

Metric Dimensions (mm) are indicated in parentheses.