

600-086 Tie-Dex II®

Micro-Tool Kit

The 600-086 Tie-Dex II® Micro-Tool Kit contains the 600-061 Hand Micro Banding Tool, the 600-086-1 Tension Gauge, Cutters for clamp removal, 600-055 Calibration Adjustment Key, and 600-060 Replacement Parts (Cut-off Blade Kit). The tension gauge is used to calibrate tool to 75 lbs. +2 lbs. -7 . Complete with rugged 12.00 in. x 8.75 in. x 4.00 in. (304.8 x 222.3 x 101.9mm) foam padded carrying case and operator's manual.

Reference: **BAND-IT®** part number **A59099**.

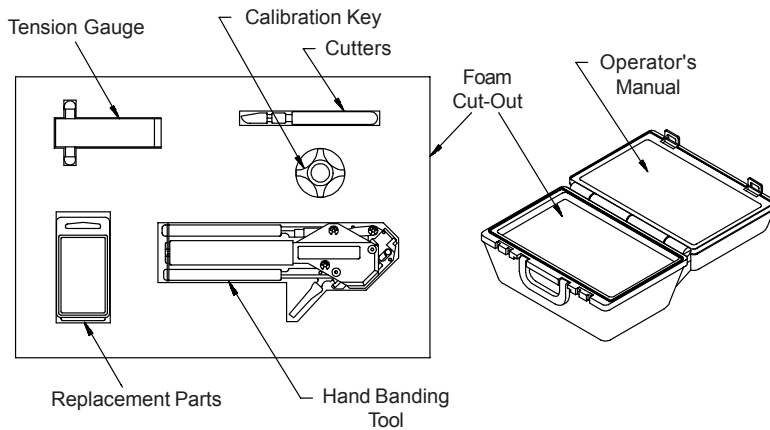

600-072 Tie-Dex II® Tool Kit

The 600-072 Tie-Dex II® Tool Kit contains the 600-058 Hand Banding Tool, the 600-072-1 Tension Gauge, Cutters for clamp removal, 600-055 Calibration Adjustment Key, and 600-056 Replacement Parts (Cut-off Blade Kit). The tension gauge is used to calibrate tool to 150 ±5 lbs. Complete with rugged 12.00 in. x 8.75 in. x 4.00 in. (304.8 x 222.3 x 101.9mm) foam padded carrying case and operator's manual.

Reference: **BAND-IT®** part number **A49099**.

Metric Dimemnsions (mm) are indicated in parentheses.