

## Hand Banding Tool 600-058

**The 600-058 Hand Banding Tool** weighs 1.18 lbs., and is designed for standard clamping bands 600-052 and 600-090 (see page J-14) in a tension range from 100 to 180 lbs. Calibrate at 150 lbs.  $\pm$  5 lbs. for most shield terminations. Tool and band should never be lubricated.

Reference: **BAND-IT®** part number **A40199**.

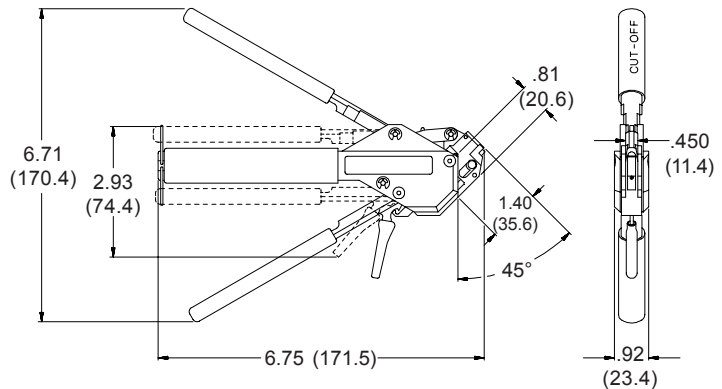

## Hand Micro Banding Tool 600-061

**The 600-061 Hand Micro Banding Tool** weighs 1.18 lbs., and is designed for micro clamping bands 600-057 and 600-083 (see page J-14) in a tension range from 50 to 85 lbs. Calibrate at 75lbs +2 lbs. -7 lbs. for most shield terminations. Tool and band should never be lubricated.

Reference: **BAND-IT®** part number **A30199**.

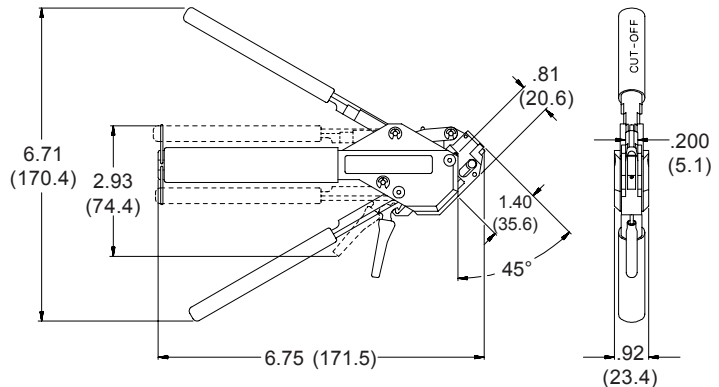

Metric Dimensions (mm) are indicated in parentheses.