

**Hand-Held  
Torque Wrench  
600-004**

**With Lighted Electric Signal**

Adjustable to desired torque level of  
0 to 150 inch pounds.

3/8" Drive

Requires two Panasonic SR44W  
or equivalent batteries

**Bench-Mounted  
Torque Wrench  
600-007**

**With Audible Electric Signal**

Adjustable to desired torque level  
of 0 to 150 inch pounds.

3/8" Drive

Requires one Panasonic SR44W  
or equivalent battery

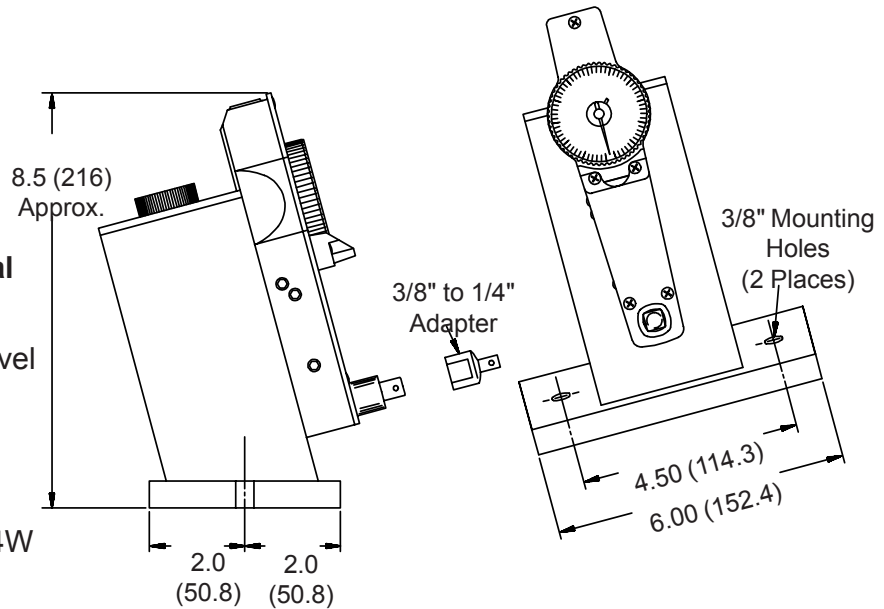

Metric Dimensions (mm) are indicated in parentheses.