

712S271 Composite Dual EMI/RFI Shield Termination Conduit Fitting For Glenair Series 74 Helical Convulsed Tubing

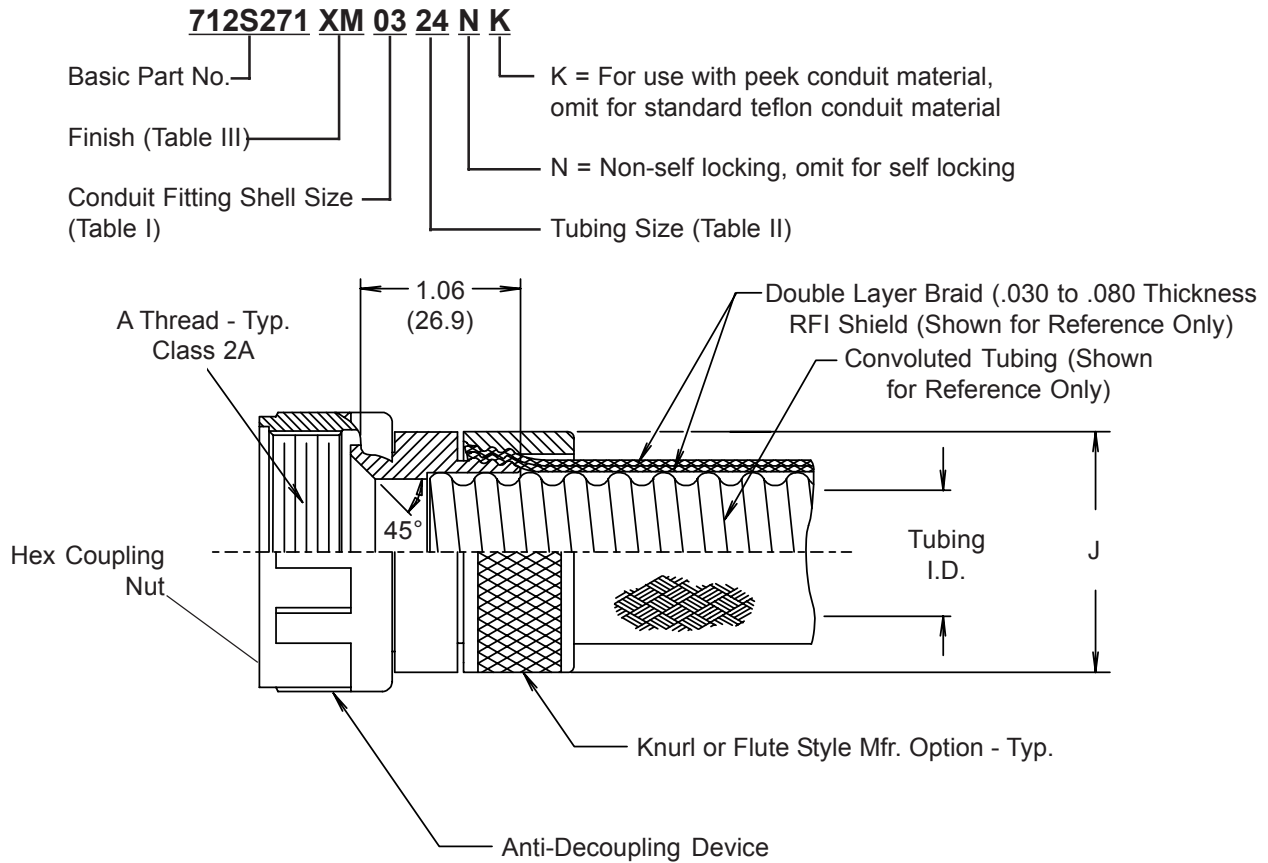

TABLE I: CONDUIT FITTING SHELL SIZE

Shell Size	A Thread Unified	Max Conduit Size Table 2	Weight in Pounds Max.
01	.750 - 20	16	.035
02	1.000 - 20	24	.047
03	1.312 - 18	32	.062
04	1.500 - 18	40	.077
05	2.000 - 18	64	.104
06	.500 - 20	09	.030
07	.625 - 24	12	.031

TABLE III: FINISH

XM	Electroless Nickel
XW	Cadmium Olive Drab Over Electroless Nickel
XB	No Plating - Black Material
XO	No Plating - Base Material Non-conductive

TABLE II: TUBING SIZE

Tubing Size	Conduit I.D.	J Dia Max
06	.188 (4.8)	.790 (20.1)
09	.281 (7.1)	.985 (25.0)
10	.312 (7.9)	.985 (25.0)
12	.375 (9.5)	1.035 (26.3)
14	.437 (11.1)	1.100 (27.9)
16	.500 (12.7)	1.160 (29.5)
20	.625 (15.9)	1.285 (32.6)
24	.750 (19.1)	1.480 (37.6)
28	.875 (22.2)	1.670 (42.4)
32	1.000 (25.4)	1.720 (43.7)
40	1.250 (31.8)	2.100 (53.3)
48	1.500 (38.1)	2.420 (61.5)
56	1.750 (44.5)	2.660 (67.6)
64	2.000 (50.8)	2.910 (73.9)

Metric dimensions (mm) are in parentheses and are for reference only.