

710-320 Composite Split Junction Fitting Straight with 45° Branch Configuration

710-320 XM 03*04*05*

Basic Part No. ————
 Finish (Table II) ————
 End A Dash No. (Table I) ————
 End C Dash No. (Table I) ————
 End B Dash No. (Table I) ————

* When all ends are identical, insert only one dash number. When multiple dash numbers are ordered, transition size will be determined by the largest. Adapter may be supplied on smaller entries. Letter to follow entry will be supplied with adapters.

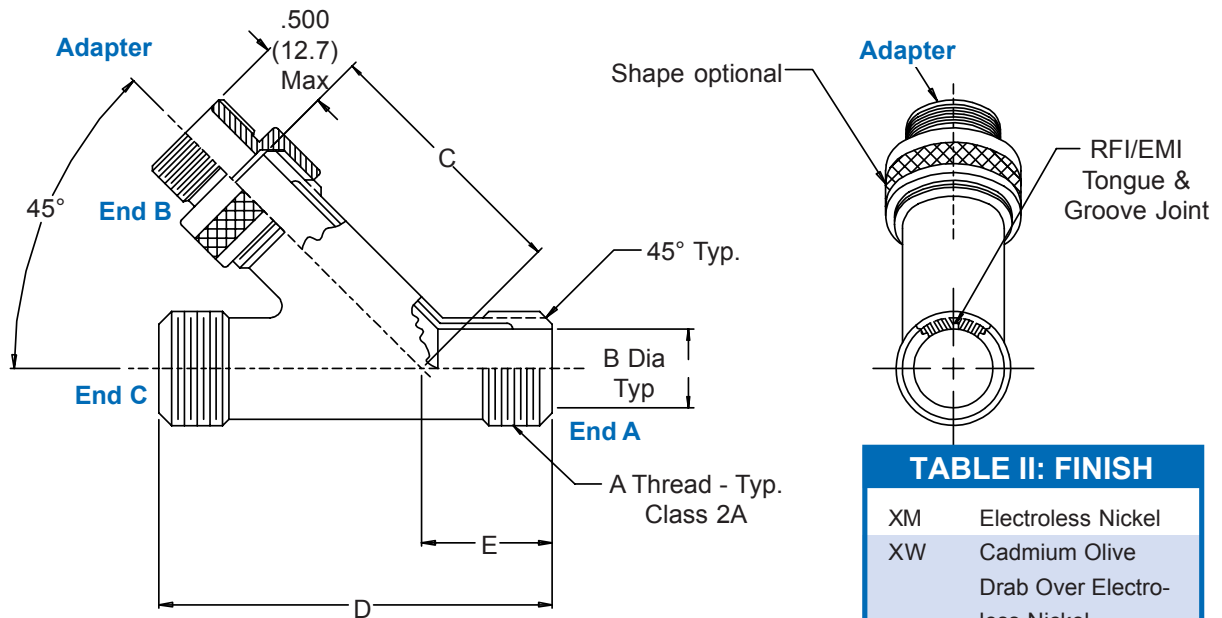

TABLE II: FINISH

XM	Electroless Nickel
XW	Cadmium Olive Drab Over Electroless Nickel
XB	No Plating - Black Material
XO	No Plating - Base Material Non-conductive

TABLE I: END ORDER NUMBER AND DIMENSIONS

End No.	A Thread		B Dia	C Max	D Max	E Max	Weight in Pounds Max.
	Unified						
01	.750 - 20		.500 (12.7)	2.250 (57.2)	3.000 (76.2)	1.125 (28.6)	.093
02	1.000 - 20		.750 (19.1)	2.500 (63.5)	3.375 (85.7)	1.188 (30.2)	.132
03	1.312 - 18		1.000 (25.4)	2.875 (73.0)	4.000 (101.6)	1.333 (33.9)	.192
04	1.500 - 18		1.250 (31.8)	3.125 (79.4)	4.375 (111.1)	1.458 (37.0)	.235
05	2.000 - 18		1.625 (41.3)	3.625 (92.1)	5.125 (130.2)	1.708 (43.4)	.347
06	.500 - 20		.281 (7.1)	1.750 (44.5)	2.625 (66.7)	1.000 (25.4)	.034
07	.625 - 24		.375 (9.5)	2.062 (52.4)	2.750 (69.9)	1.062 (27.0)	.047

1. Metric dimensions (mm) are in parentheses and are for reference only.
2. Consult factory for availability.