

**107-044**  
**Nickel Plated Copper**  
**EMI/RFI Environmental Knit Braid**  
 for use with Knit Braid Adapters 380-130, 380-131 and 380-132



Composite Backshells

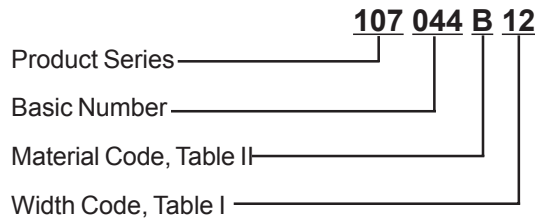
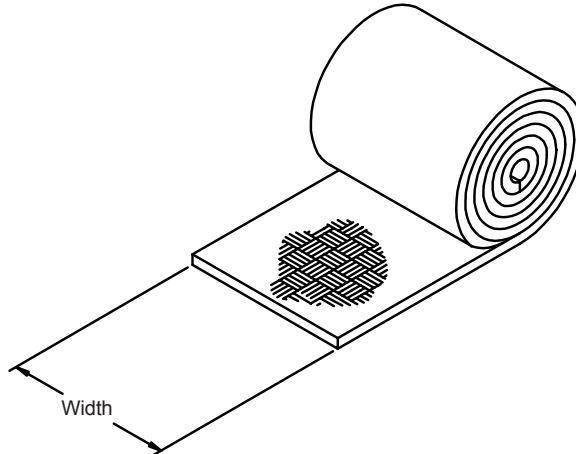

TABLE I: SIZE				
Width Code	Width	Strands Diameter	Approx. No. of Stitches per CM on Length	Approx. No. of Stitches per CM Across Length
12	.472 (12.0)	.006 (0.2)	.138 (3.5)	.173 (4.4)

TABLE II: MATERIAL	
B *	Nickel Plated Copper

\* For other material options and sizes please consult factory

**NOTES:**

1. The woven braid is to be used with 360° RFI/EMI shield terminations.
2. Metric dimensions (mm) are in parentheses and are for reference only