

319-137 Composite Shield Sock Strain Relief with Self-Locking Rotatable Coupling

A

CONNECTOR DESIGNATOR:	
A	MIL-DTL-5015, -26482 Series II, and -83723 Series I and III
F	MIL-DTL-38999 Series I, II (see note 3)
H	MIL-DTL-38999 Series III and IV
SELF-LOCKING	
ROTATABLE COUPLING	
LOW PROFILE	

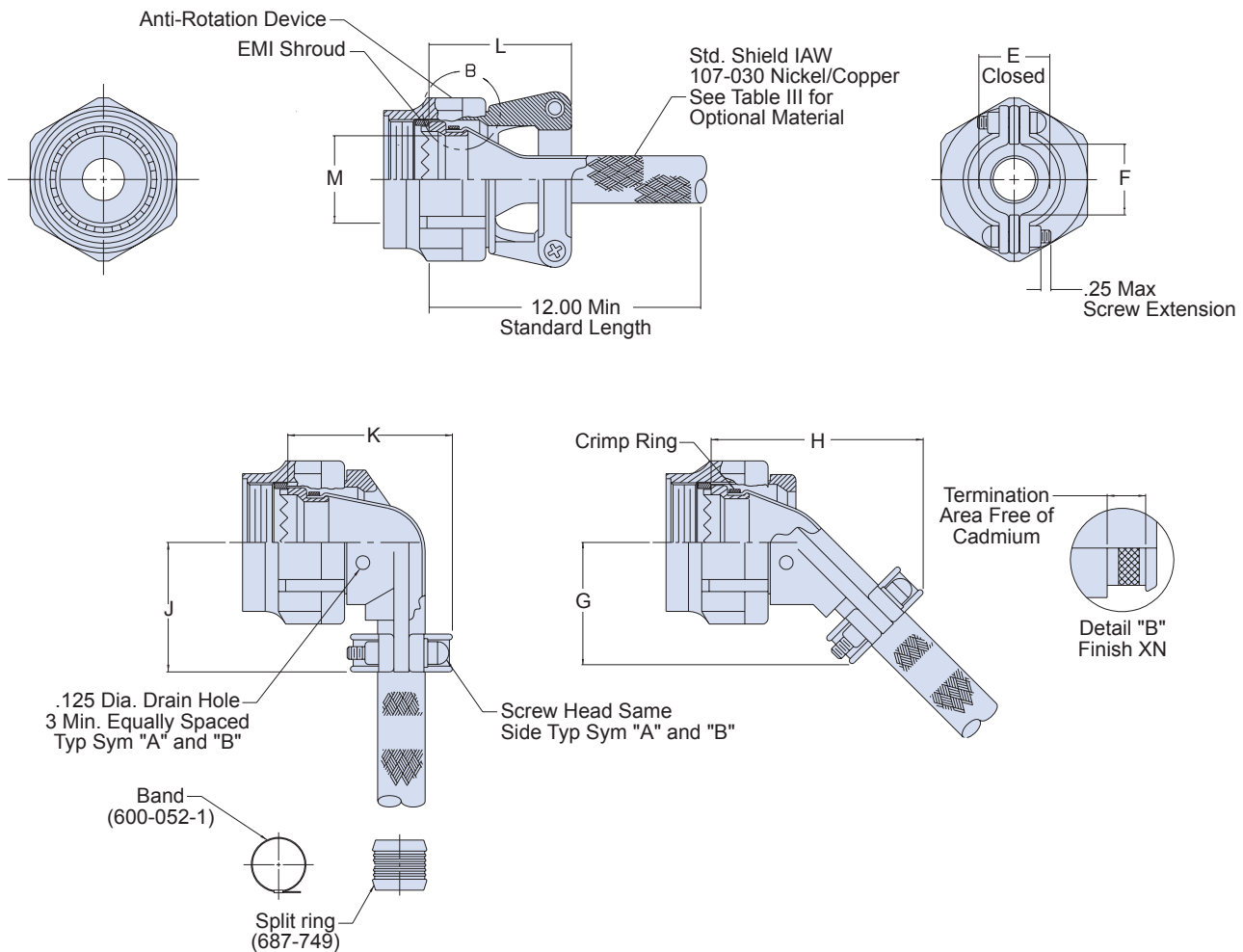
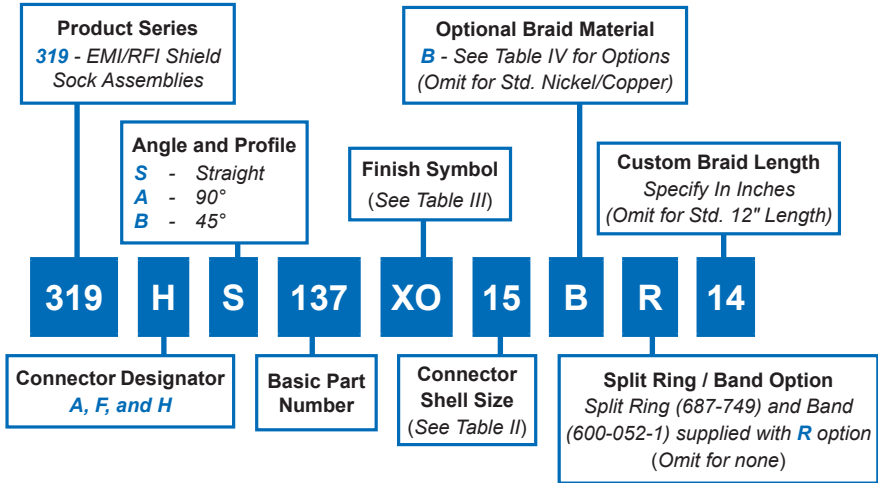

319-137 Composite Shield Sock Strain Relief with Self-Locking Rotatable Coupling



Composite
Backshells

A

TABLE II: SHELL SIZE

Shell Size		E ± .031	F Min	G Max	H Max
A, F	H				
08	09	.265 (6.7)	.22 (5.6)	.901 (22.9)	1.388 (35.3)
10	11	.310 (7.9)	.27 (6.9)	.964 (24.5)	1.428 (36.3)
12	13	.390 (9.9)	.35 (8.9)	1.050 (26.7)	1.498 (38.0)
14	15	.506 (12.9)	.47 (11.9)	1.112 (28.2)	1.548 (39.3)
16	17	.591 (15.0)	.55 (14.0)	1.175 (29.8)	1.648 (41.9)
18	19	.661 (16.8)	.62 (15.7)	1.230 (31.2)	1.768 (44.9)
20	21	.744 (18.9)	.70 (17.8)	1.293 (32.8)	1.808 (45.9)
22	23	.826 (21.0)	.78 (19.8)	1.365 (34.7)	1.858 (47.2)
24	25	.896 (22.8)	.85 (21.6)	1.417 (36.0)	1.898 (48.2)

TABLE II: SHELL SIZE (CONTINUED)

Shell Size		J Max	K Max	L Max	K Diameter		
A, F	H				A Code	F Code	H Code
08	09	.91 (23.1)	1.128 (28.7)	.939 (23.9)	.265 (6.7)	.275 (7.0)	.264 (6.7)
10	11	.97 (24.6)	1.168 (29.7)	1.059 (26.9)	.370 (9.4)	.412 (10.5)	.390 (9.9)
12	13	1.06 (26.9)	1.248 (31.7)	1.199 (30.5)	.506 (12.9)	.526 (13.4)	.504 (12.8)
14	15	1.16 (29.5)	1.368 (34.7)	1.199 (30.5)	.580 (14.7)	.651 (16.5)	.630 (16.0)
16	17	1.34 (34.0)	1.448 (36.8)	1.329 (33.8)	.705 (17.9)	.776 (19.7)	.756 (19.2)
18	19	1.41 (35.8)	1.528 (38.8)	1.509 (38.3)	.784 (19.9)	.872 (22.1)	.843 (21.4)
20	21	1.53 (38.9)	1.648 (41.9)	1.609 (40.9)	.909 (23.1)	1.007 (25.6)	.969 (24.6)
22	23	1.66 (42.2)	1.688 (42.9)	1.759 (44.7)	1.034 (1.034)	1.132 (28.8)	1.091 (27.7)
24	25	1.78 (45.2)	1.758 (44.7)	1.859 (47.2)	1.149 (29.2)	1.257 (31.9)	1.217 (30.9)

TABLE III: FINISH

Symbol	Finish
XB	Composite Material—No Plating, Color Black, Brass Interface Shroud and Adapter—Nickel Plated
XMT	2000 Hour Corrosion Resistant Ni-PTFE, Nickel-Fluorocarbon Polymer. 1000 Hour Grey™
XN	Composite Material—No Plating, Color Black and Brown, Brass Interface Shroud and Adapter—Selectively Cadmium Plated (See Detail B)

TABLE IV: BRAID TYPE

Symbol	Braid Type
A	100% AmberStrand®
B	75%/25% AmberStrand® Blend
L	100% ArmorLite™
Standard	Nickel/Copper 34awg
T	Tin/Copper 34awg

NOTES

1. See composite thermoplastic shield sock assembly procedure for detailed installation instructions.
2. See Table I in Intro for front-end dimensional details.
3. Add mod code -475 to end of part number for use with Series II connectors. Backshell to be supplied less shroud.
4. Coupling nut supplied unplated.