

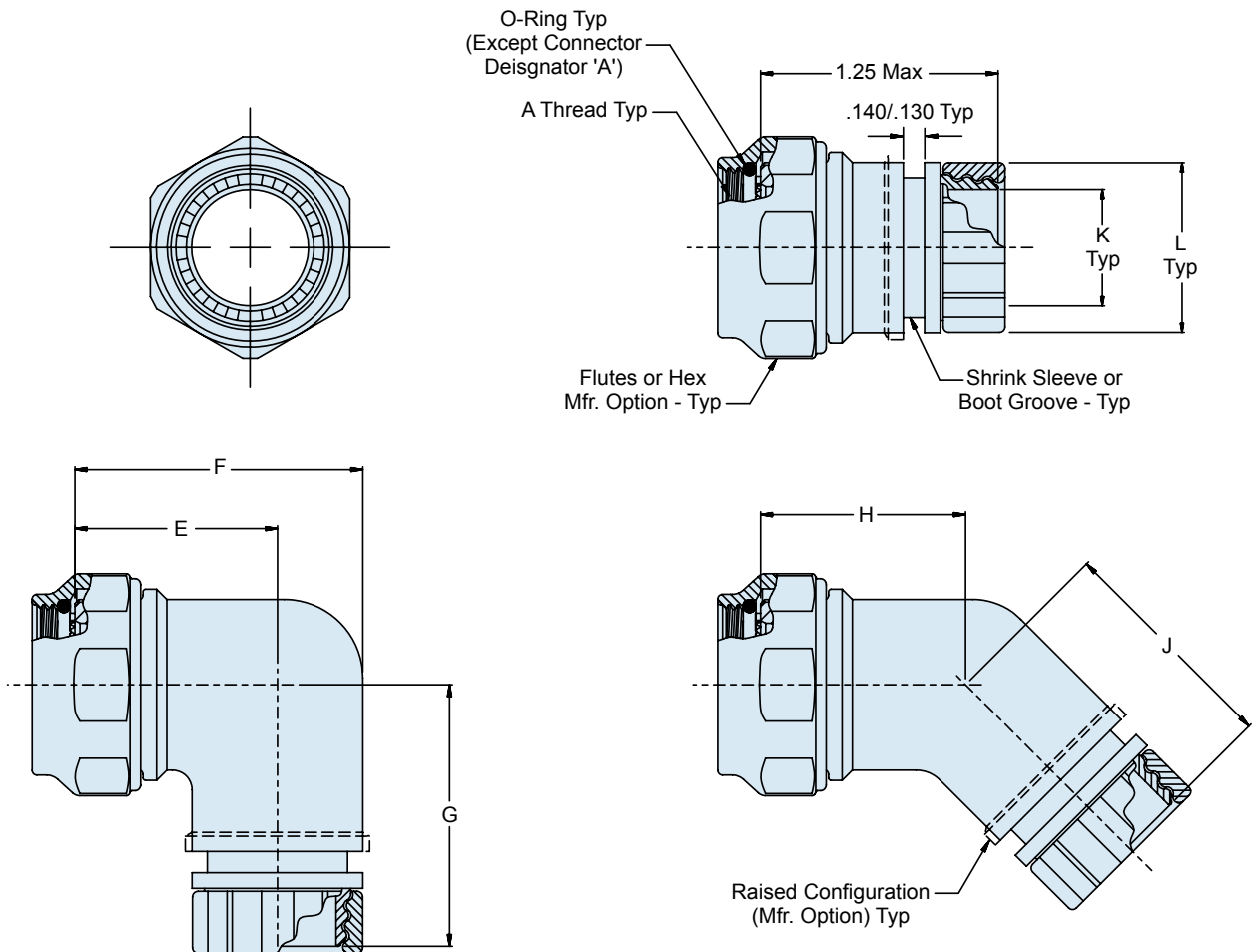

311-019 Composite Lamp Base Thread EMI/RFI Shield Termination Backshell with Shrink Boot Porch and Self-Locking Rotatable Coupling

A

CONNECTOR DESIGNATOR:	
A	MIL-DTL-5015, -26482 Series II, and -83723 Series I and III
F	MIL-DTL-38999 Series I, II
H	MIL-DTL-38999 Series III and IV
SELF-LOCKING	
ROTATABLE COUPLING	
STANDARD PROFILE	

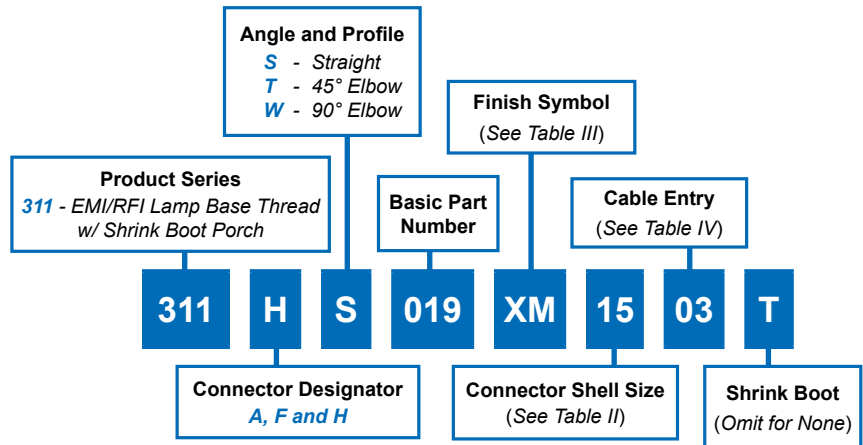

311-019
Composite Lamp Base Thread
EMI/RFI Shield Termination Backshell
with Shrink Boot Porch and Self-Locking Rotatable Coupling



TABLE II: SHELL SIZE

Shell Size		E ± .06	F ± .09	G ± .09	H ± .06	J ± .09	Max Dash Number (Table II)
A, F	H						
08	09	0.69 (17.5)	0.88 (22.4)	1.19 (30.2)	0.72 (18.3)	1.00 (25.4)	02
10	11	0.75 (19.1)	1.00 (25.4)	1.25 (31.8)	0.75 (19.1)	1.06 (26.9)	03
12	13	0.81 (20.6)	1.13 (28.7)	1.31 (33.3)	0.75 (19.1)	1.13 (28.7)	04
14	15	0.88 (22.4)	1.31 (33.3)	1.38 (35.1)	0.76 (19.3)	1.16 (29.5)	05
16	17	0.94 (23.9)	1.38 (35.1)	1.44 (36.6)	0.78 (19.8)	1.18 (30.0)	06
18	19	0.97 (24.6)	1.44 (36.6)	1.47 (37.3)	0.79 (20.1)	1.19 (30.2)	07
20	21	1.06 (26.9)	1.63 (41.4)	1.56 (39.6)	0.82 (20.8)	1.22 (31.0)	08
22	23	1.13 (28.7)	1.75 (44.5)	1.63 (41.4)	0.86 (21.8)	1.26 (32.0)	09
24	25	1.19 (30.2)	1.88 (47.8)	1.69 (42.9)	0.89 (22.6)	1.29 (32.8)	10

TABLE IV: ENTRY DIAMETER

Dash Number	K Entry ± .03	L ± .06
01	.13 (3.3)	.45 (11.4)
02	.25 (6.4)	.52 (13.2)
03	.38 (9.7)	.64 (16.3)
04	.50 (12.7)	.77 (19.6)
05	.63 (16.0)	.92 (23.4)
06	.75 (19.1)	1.02 (25.9)
07	.81 (20.6)	1.14 (29.0)
08	.94 (23.9)	1.27 (32.3)
09	1.06 (26.9)	1.43 (36.3)
10	1.19 (30.2)	1.52 (38.6)
11	1.38 (35.1)	1.64 (41.7)

TABLE III: FINISH

Symbol	Finish Description
XM	2000 Hour Corrosion Resistant Electroless Nickel
XMT	2000 Hour Corrosion Resistant Ni-PTFE, Nickel-Fluorocarbon Polymer. <i>1000 Hour Grey™</i>
XW	2000 Hour Corrosion Resistant Cadmium/Olive Drab over Electroless Nickel

NOTES

1. See Table I in Intro for front-end dimensional details.
2. 770-001S**-0 shrink boot supplied with T option. See shrink boot product page for more details.
3. O-Ring will not be supplied with Connector Designator A.
4. Coupling nut supplied unplated.