

Series 140-203 12 Port Rectangular Junction Box

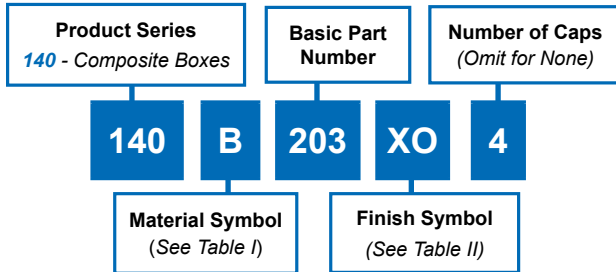

Symbol	Finish Description
XO	No Plating (Non-Conductive Finish)
XMS	Internal Surfaces - Electroless Nickel External Surfaces - See Table I
XM	All Surfaces - Electroless Nickel
XW	All Surfaces - Cadmium Olive Drab over Electroless Nickel
XZN	All Surfaces - Zinc Nickel/Black
XMT	2000 Hour Corrosion Resistant Ni-PTFE, Nickel-Fluorocarbon Polymer. 1000 Hour Grey™

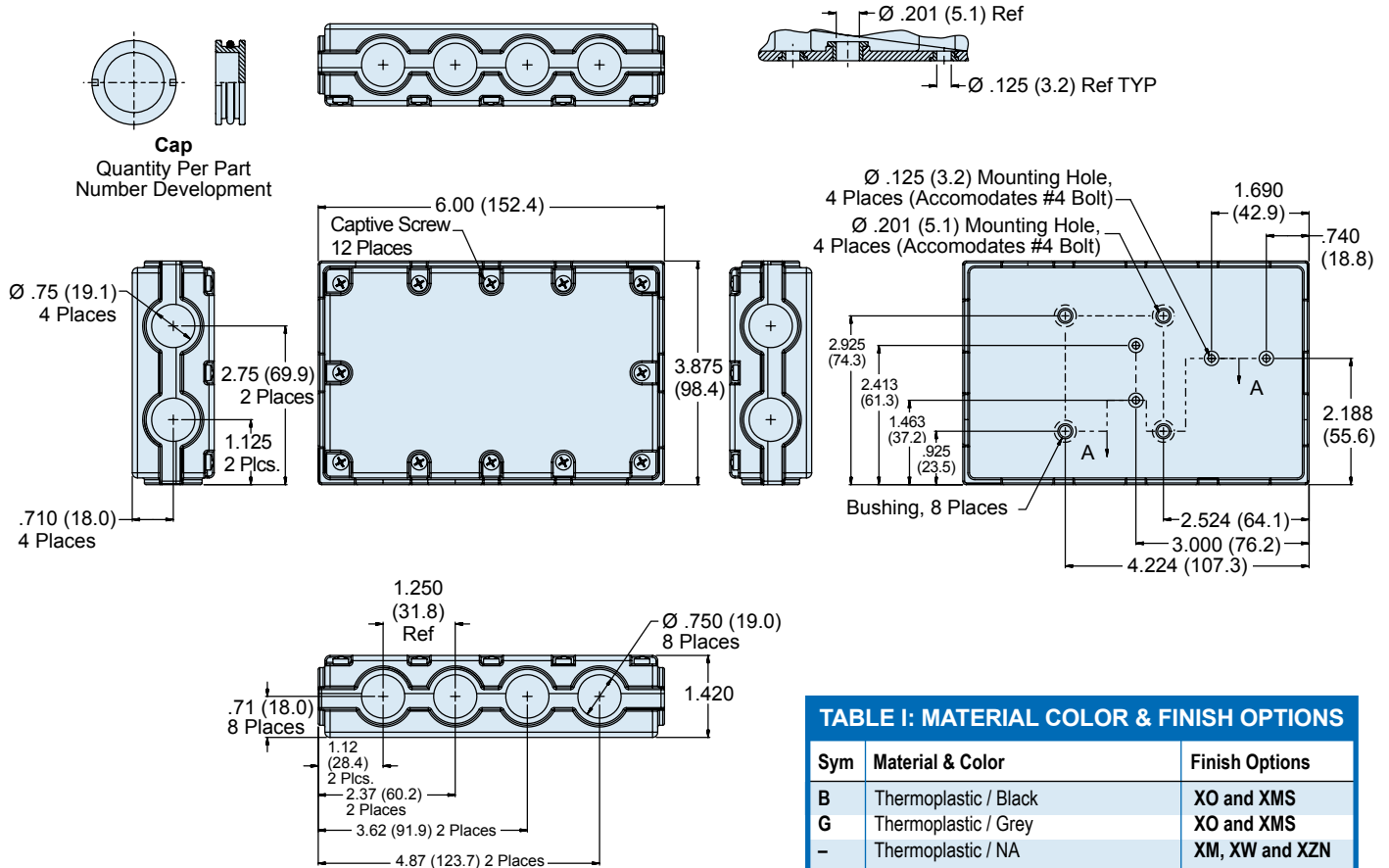

Sym	Material & Color	Finish Options
B	Thermoplastic / Black	XO and XMS
G	Thermoplastic / Grey	XO and XMS
-	Thermoplastic / NA	XM, XW and XZN

- NOTES**
- Box series numbers are for reference only. Please complete the worksheet on E-14 and call the factory for part number assignment for your specific box configuration.
 - Metric dimensions (mm) are in parentheses and for reference only.

