

A

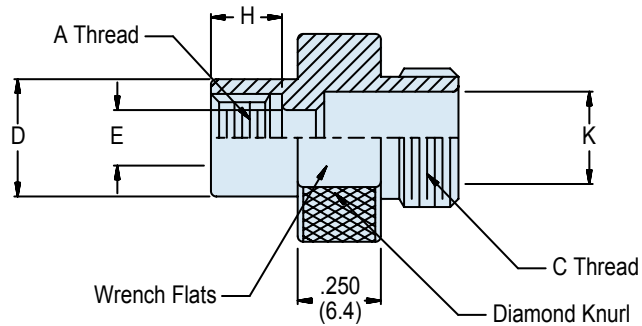
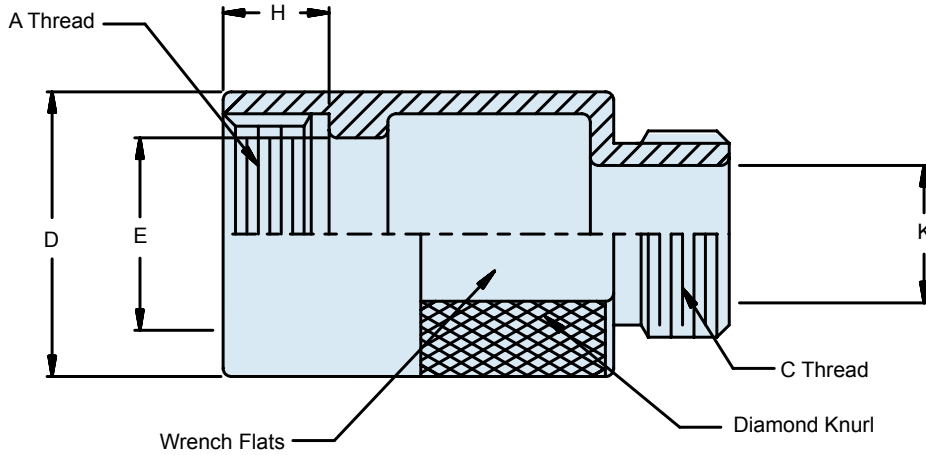
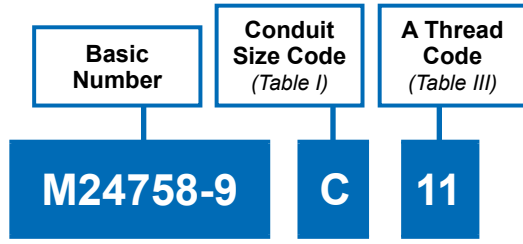

Optional Configuration Supplied  
when E Diameter is Equal or Less than K Diameter

TABLE I		
CONDUIT SIZE CODE	C CLASS - 2A THREAD	K DIA MIN
A	.438-28 UNEF	.245 (6.22)
B	.688-24 UNEF	.490 (12.57)
C	.938-20 UNEF	.745 (18.92)
D	1.250-18 UNEF	.995 (25.27)
E	1.563-18 UNEF	1.245 (31.62)
F	1.875-16 UN	1.495 (37.97)
G	2.375-16 UN	1.995 (50.67)
H	2.875-16 UN	2.495 (63.37)
J	.563-24 UNEF	.370 (9.40)
K	.813-20 UNEF	.620 (15.75)
L	3.375-16 UN	2.995 (76.07)

APPLICATION NOTES

1. Assembly identified with manufacturer's code identification number (Glenair, part number and classification code 490).
2. The function of the M24758-9 couples MIL-C-5015 connectors (MS3100, MS3101, MS3106 and MS-series end bells) to M24758-2, MS24758-3 or M24758-4 fittings.
3. For MIL-DTL-5015, MS3400 series, the M24758-13 adapter shall be used.
4. See Table III for A Thread torque values.
5. Material / Finish:  
Adapter - 316 / electroless nickel, matte finish
6. Metric dimensions (mm) are indicated in parentheses.

# MIL-PRF-24758-9 Adapter for MS3100 Series MIL-DTL-5015 Connectors



MIL-PRF  
24758A

A

TABLE II: MIL-DTL-5015 CONNECTOR CODE

CONNECTOR CODE	CLASS	MANUFACTURER	SERIES
A		All Manufacturers	MS-Series Endbell
B	A	Amphenol	MS3100, MS3101, MS3106, 97-3100, 97-3101, 97-3106
C	E & R	Amphenol	MS3100, MS3101, MS3106, 97-3100, 97-3101, 97-3106
D	A, E & R	Bendix	MS3100, MS3101, MS3106, 10-214, 10-720, 10-721, 10-726
E	A	Cannon	MS3100, MS3101, MS3106, CA3101, CA3106
F	E & R	Cannon	MS3100, MS3101, MS3106

TABLE III: A-THREAD CODE AND ADAPTER DIMENSIONS

A THREAD CODE	CONNECTOR SHELL SIZE	CONNECTOR CODE (SEE TABLE II)	A CLASS-2B THREAD	D DIA ±.02 (0.5)	E DIA ±.02 (0.5)	H ±.02 (0.5)	A THREAD TORQUE VALUES
01	8S	D	.375-32 UNEF	.500 (12.70)	.280 (7.11)	.180 (4.6)	40 inch lbs.
02	8S	B	.438-27 UNS	.560 (14.22)	.340 (8.64)	.210 (5.3)	40 inch lbs.
03	8	C, E, F	.438-28 UNEF	.560 (14.22)	.340 (8.64)	.210 (5.3)	40 inch lbs.
04	8S	A	.500-28 UNEF	.620 (15.75)	.370 (9.40)	.210 (5.3)	40 inch lbs.
04	10S	A, B, C, D, E	.500-28 UNEF	.620 (15.75)	.370 (9.40)	.210 (5.3)	40 inch lbs.
05	10S	E	.563-24 UNEF	.680 (17.27)	.450 (11.43)	.250 (6.4)	40 inch lbs.
05	10SL	E, F	.563-24 UNEF	.680 (17.27)	.450 (11.43)	.250 (6.4)	40 inch lbs.
06	10SL	A, B, C, D	.625-24 UNEF	.750 (19.05)	.500 (12.70)	.250 (6.4)	40 inch lbs.
06	12, 12S	A, D, F	.625-24 UNEF	.810 (20.57)	.570 (14.48)	.250 (6.4)	40 inch lbs.
07	12, 12S	B, C, E	.688-24 UNEF	.810 (20.57)	.570 (14.48)	.250 (6.4)	40 inch lbs.
08	12SL	A	.750-20 UNEF	.870 (22.10)	.620 (15.75)	.280 (7.1)	40 inch lbs.
08	14, 14S	A, B, C, D, E, F	.750-20 UNEF	.870 (22.10)	.620 (15.75)	.280 (7.1)	40 inch lbs.
09	16, 16S	A, B, C, D, E, F	.875-20 UNEF	1.000 (25.40)	.750 (19.05)	.280 (7.1)	40 inch lbs.
10	18	A, B, C, D, E, F	1.000-20 UNEF	1.120 (28.45)	1.000 (25.40)	.280 (7.1)	40 inch lbs.
12	20	C	1.125-18 UNS	1.250 (31.75)	1.000 (25.40)	.280 (7.1)	80 inch lbs.
13	20, 22	A	1.188-18 UNEF	1.310 (33.27)	1.060 (26.92)	.280 (7.1)	80 inch lbs.
14	22	B, C, D, E, F	1.250-18 UNEF	1.370 (34.80)	1.120 (28.45)	.280 (7.1)	80 inch lbs.
15	24	B, C, D, E, F	1.375-18 UNEF	1.500 (38.10)	1.250 (31.75)	.280 (7.1)	80 inch lbs.
16	24, 28	A	1.438-18 UNEF	1.560 (39.62)	1.310 (33.27)	.280 (7.1)	120 inch lbs.
17	28	B, C, D, E, F	1.625-18 UNEF	1.750 (44.45)	1.500 (38.10)	.280 (7.1)	120 inch lbs.
18	32	A	1.750-18 UNS	1.870 (47.50)	1.620 (41.15)	.280 (7.1)	120 inch lbs.
19	32	D, E, F	1.875-16 UN	2.000 (50.80)	1.750 (44.45)	.280 (7.1)	120 inch lbs.
20	32	B, C	1.906-18	2.030 (51.56)	1.780 (45.21)	.280 (7.1)	120 inch lbs.
21	36	A	2.000-18 UNS	2.120 (53.85)	1.870 (47.50)	.310 (7.9)	120 inch lbs.
22	36	D	2.063-16 UNS	2.180 (55.37)	1.930 (49.02)	.280 (7.1)	120 inch lbs.
23	36	C	2.063-20	2.180 (55.37)	1.930 (49.02)	.310 (7.9)	120 inch lbs.
24	36	E, F	2.125-16 UN	2.250 (57.15)	2.000 (50.80)	.280 (7.1)	120 inch lbs.
25	36	B	2.125-18	2.250 (57.15)	2.000 (50.80)	.310 (7.9)	120 inch lbs.
27	40	D	2.313-16 UNS	2.430 (61.72)	2.180 (55.37)	.310 (7.9)	160 inch lbs.
28	40	B, E, F	2.375-16 UN	2.500 (63.50)	2.250 (57.15)	.310 (7.9)	160 inch lbs.
29	44	B, F	2.625-16 UN	2.750 (69.85)	2.500 (63.50)	.310 (7.9)	160 inch lbs.
30	48	F	2.813-18	2.930 (74.42)	2.680 (68.07)	.280 (7.1)	160 inch lbs.
31	48	B	2.875-16 UN	3.000 (76.20)	2.750 (69.85)	.310 (7.9)	160 inch lbs.