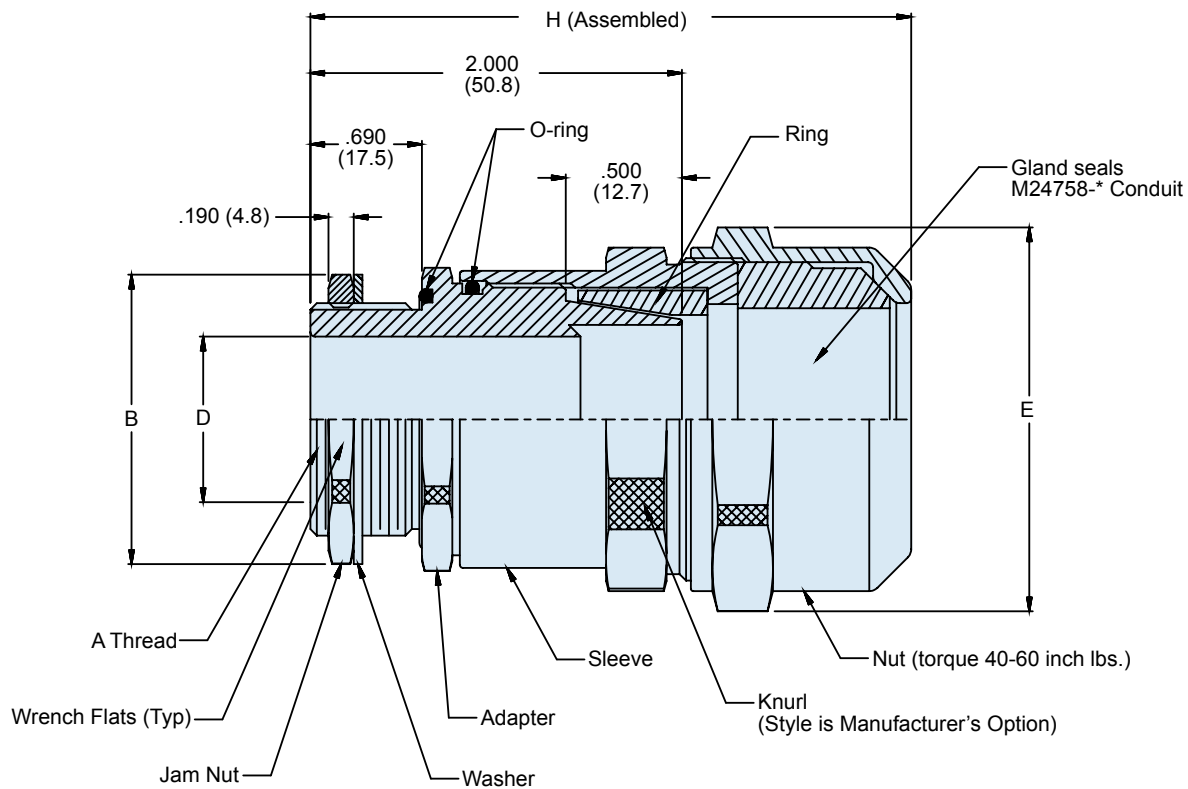

A

**Basic
Number**
**Conduit
Size Code**
(Table I)
M24758-5
C

APPLICATION NOTES

1. Assembly identified with manufacturer's code identification number (Glenair, part number and classification code 490).
2. The function of the M24758-5 fitting is to terminate M24758-* flexible shielding conduit directly to a panel.
3. Lubricate with anti-seize compound (NSN-8030-01-450-4009).
4. Material / Finish:
5. Adapter, nuts, sleeve & ring - 316 SST/Electroless nickel, matte finish.
O-ring and gland - Silicone rubber / NA.
Washer - 316 SST/Passivate.
4. Metric dimensions (mm) are indicated in parentheses.

MIL-PRF-24758-5
Straight Conduit to Panel Fitting



MIL-PRF
24758A

A

TABLE I				
CONDUIT SIZE CODE	A CLASS - 2A THREAD	B DIA ±.06 (1.5)	D DIA MIN	E MAX DIA
A	.625-24 UNEF	1.000 (25.40)	.245 (6.2)	1.140 (29.0)
B	.875-20 UNEF	1.250 (31.75)	.495 (12.6)	1.460 (37.1)
C	1.188-18 UNEF	1.562 (39.67)	.745 (18.9)	1.780 (45.2)
D	1.438-18 UNEF	1.812 (46.02)	.995 (25.3)	1.030 (26.2)
E	1.750-16 UN	2.125 (53.98)	1.245 (31.6)	2.280 (57.9)
F	2.000-16 UN	2.375 (60.33)	1.495 (38.0)	2.530 (64.3)
G	2.500-16 UN	2.875 (73.03)	1.995 (50.7)	3.140 (79.8)
H	3.000-16 UN	3.375 (85.73)	2.495 (63.4)	3.650 (92.7)
J	.750-20 UNEF	1.125 (28.58)	.370 (9.4)	1.340 (34.0)
K	1.000-20 UNEF	1.500 (38.10)	.620 (15.7)	1.650 (41.9)
L	3.500-16 UN	3.750 (95.3)	2.995 (76.1)	4.150 (105.4)

TABLE II RECOMMENDED TORQUE (See Note 3)		
CONDUIT SIZE CODE	± 5 Inch lbs.	
	A THREAD	SLEEVE
A	40	120
B	45	140
C	50	150
D	80	170
E	80	170
F	80	170
G	80	170
H	80	170
J	45	120
K	50	140
L	80	170