

A

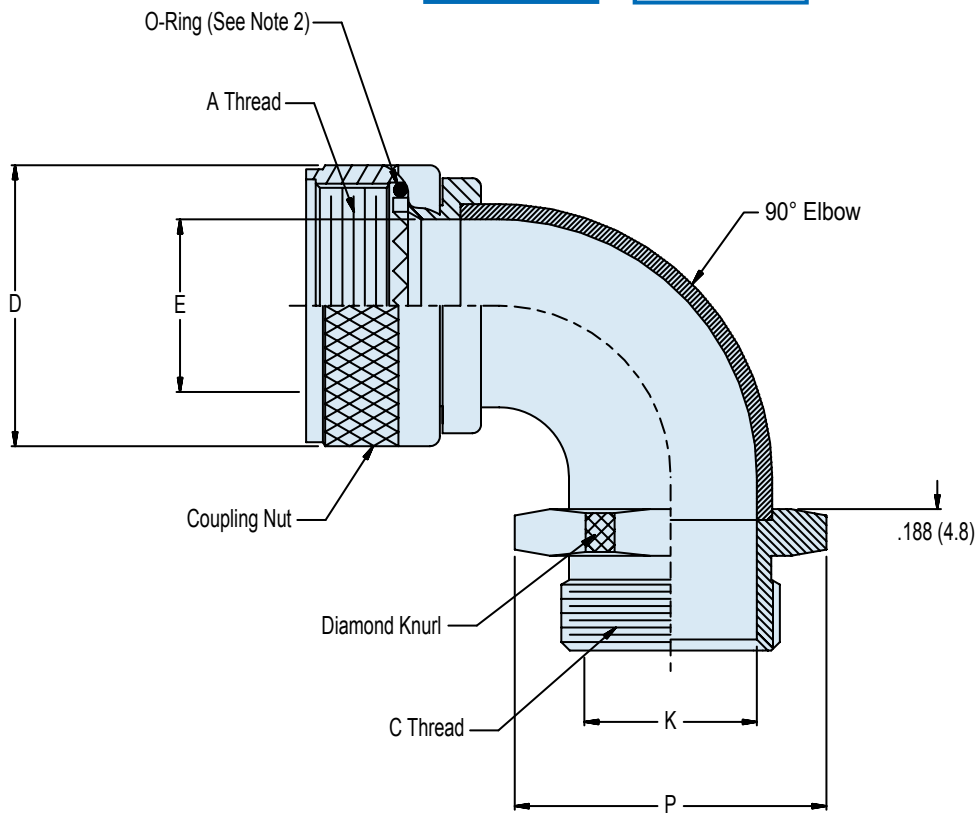
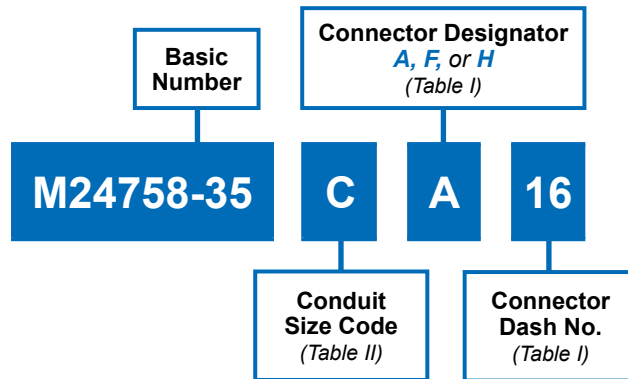

APPLICATION NOTES

1. Assembly identified with manufacturer's code identification number (Glenair, part number and classification code 490).
2. O-Ring not supplied with connector designator A.
3. See Glenair Circular Connector Accessories catalog for recommended torque values, Group 2.
4. Material / Finish:
Elbow, coupling nut - 316 SST/Electroless nickel, matte finish.
O-Ring - Silicone rubber/NA
5. Metric dimensions (mm) are indicated in parentheses.

MIL-PRF-24758-35

90° Elbow for Connectors Listed in Table I



MIL-PRF
24758A

A

TABLE I: Dimensions for CONNECTOR DESIGNATOR A (See Note 2)

Connector Dash No.	NAS 1599 and MIL-DTL-83723 Series I and III	MIL-DTL-5015 (MS3400 Series)	AS81703 (Navy) Series III	MIL-DTL-26482 Series II	A Thread Class - 2B	D Dia Max	E Dia Ref
03	—	—	03	—	.562-24 UNEF	.669 (17.0)	.270 (6.9)
08	08	8S	—	08	.500-20 UNF	.617 (15.7)	.270 (6.9)
10	10	10S, 10SL	—	10	.624-24 UNEF	.734 (18.6)	.375 (9.5)
12	12	12, 12S	07	12	.750-20 UNEF	.858 (21.8)	.511 (13.0)
14	14	14, 14S	12	14	.875-20 UNEF	.984 (25.0)	.585 (14.9)
16	16	16, 16S	19	16	1.000-20 UNEF	1.112 (28.2)	.710 (18.0)
18	18	18	27	18	1.062-18 UNEF	1.218 (30.9)	.789 (20.0)
20	20	20	37	20	1.188-18 UNEF	1.345 (34.2)	.914 (23.2)
22	22	22	—	22	1.312-18 UNEF	1.468 (37.3)	1.039 (26.4)
24	24	24	—	24	1.438-18 UNEF	1.593 (40.5)	1.154 (29.3)
28	—	28	—	—	1.750-18 UNS	1.969 (50.0)	1.389 (35.3)
32	—	32	—	—	2.000-18 UNS	2.219 (56.4)	1.635 (41.5)
36	—	36	—	—	2.250-16 UN	2.469 (62.7)	1.850 (47.0)
40	—	40	—	—	2.500-16 UN	2.719 (69.1)	2.065 (52.5)
44	—	44	—	—	3.000-16 UN	2.969 (75.4)	2.320 (58.9)
48	—	48	—	—	3.000-16 UN	3.219 (81.8)	2.570 (65.3)
61	—	—	61	—	1.500-18 UNEF	1.653 (42.0)	1.194 (30.3)

TABLE I: Dimensions for CONNECTOR DESIGNATOR F

Connector Dash No.	NAS 1599 and MIL-DTL-83723 Series I and III	A Thread Class - 2B	D Dia Max	E Dia Ref
08	08	.438-28 UNEF	.860 (21.8)	.269 (6.8)
10	10	.562-24 UNEF	.980 (24.9)	.402 (10.2)
12	12	.688-24 UNEF	1.160 (29.5)	.516 (13.1)
14	14	.812-20 UNEF	1.280 (32.5)	.641 (16.3)
16	16	.938-20 UNEF	1.410 (35.8)	.766 (19.5)
18	18	1.062-18 UNEF	1.520 (38.6)	.863 (21.9)
20	20	1.188-18 UNEF	1.640 (41.7)	.988 (25.1)
22	22	1.312-18 UNEF	1.770 (45.0)	1.113 (28.3)
24	24	1.438-18 UNEF	1.890 (48.0)	1.238 (31.4)

TABLE II: Conduit Size Code and Fitting Dimensions

Conduit Size Code	C Thread Class - 2A	K Dia Min	P Max
A	.438-28 UNEF	.245 (6.2)	.880 (22.4)
B	.562-24 UNEF	.495 (12.6)	1.130 (28.7)
C	.688-24 UNEF	.745 (18.9)	1.380 (35.1)
D	.812-20 UNEF	.995 (25.3)	1.690 (43.0)
E	.938-20 UNEF	1.245 (31.6)	2.000 (50.8)
F	1.062-18 UNEF	1.495 (38.0)	2.310 (58.7)
G	1.188-18 UNEF	1.995 (50.7)	2.940 (74.7)
H	1.312-18 UNEF	2.495 (63.4)	3.440 (87.4)
J	1.438-18 UNEF	.370 (9.4)	.940 (23.9)
K	1.438-18 UNEF	.620 (15.7)	1.190 (30.2)
L	1.750-18 UNS	2.995 (76.1)	3.940 (100.1)

TABLE I: Dimensions for CONNECTOR DESIGNATOR H

Connector Dash No.	MIL-DTL-38999 Series III & IV	A Thread	D Dia Max	E Dia Ref
09	A / 09	M12 X 1.0 -6H	.860 (21.8)	.269 (6.8)
11	B / 11	M15 X 1.0 -6H	.980 (24.9)	.402 (10.2)
13	C / 13	M18 X 1.0 -6H	1.160 (29.5)	.516 (13.1)
15	D / 15	M22 X 1.0 -6H	1.280 (32.5)	.641 (16.3)
17	E / 17	M25 X 1.0 -6H	1.410 (35.8)	.766 (19.5)
19	F / 19	M28 X 1.0 -6H	1.520 (38.6)	.863 (21.9)
21	G / 21	M31 X 1.0 -6H	1.640 (41.7)	.988 (25.1)
23	H / 23	M34 X 1.0 -6H	1.770 (45.0)	1.113 (28.3)
25	J / 25	M37 X 1.0 -6H	1.890 (48.0)	1.238 (31.4)