

A

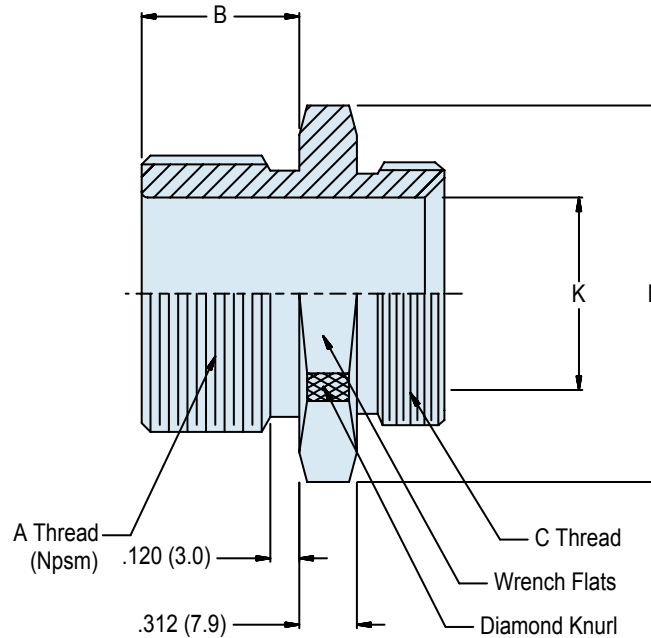
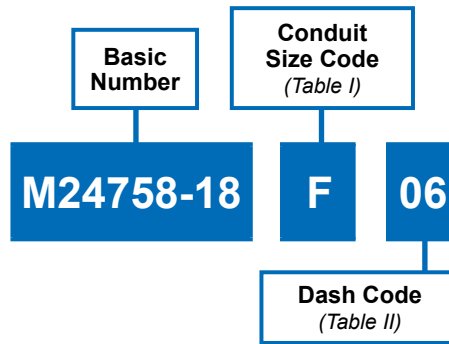

**APPLICATION NOTES**

1. Assembly identified with manufacturer's code identification number (Glenair, part number and classification code 490).
2. The M24758-18 adapter couples any fittings having a female straight pipe thread to M24758-2, M24758-3 or M24758-4 fittings.
3. Material / Finish:  
Adapter, - 316 / electroless nickel, matte finish.
4. Metric dimensions (mm) are indicated in parentheses.

**MIL-PRF-24758-18  
Adapter for Straight Pipe Thread**



MIL-PRF  
24758A

A

**TABLE I**

CONDUIT SIZE CODE	C Class 2A Thread	K DIA MIN	P DIA MAX	MAX ENTRY DASH NUMBER
A	.438-28 UNEF	.245 (6.22)	1.000 (25.40)	01
B	.688-24 UNEF	.495 (12.57)	1.250 (31.75)	03
C	.938-20 UNEF	.745 (18.92)	1.500 (38.10)	04
D	1.250-18 UNEF	.995 (25.27)	1.750 (44.45)	05
E	1.563-18 UNEF	1.245 (31.62)	2.130 (54.10)	06
F	1.875-16 UN	1.495 (37.97)	2.380 (60.45)	07
G	2.375-16 UN	1.995 (50.67)	2.880 (73.15)	08
H	2.875-16 UN	2.495 (63.37)	3.380 (85.85)	09
J	.563-24 UNEF	.370 (9.40)	1.130 (28.70)	02
K	.813-20 UNEF	.620 (15.75)	1.630 (41.40)	04
L	3.375-16 UN	2.995 (76.07)	4.130 (104.90)	10

**TABLE II**

DASH NUMBER	A EXTERNAL TAPER PIPE THREAD	B DIM ±.02 (0.5)
01	.250-18 NPSM	.750 (19.1)
02	.375-18 NPSM	.750 (19.1)
03	.500-14 NPSM	.870 (22.1)
04	.750-14 NPSM	.870 (22.1)
05	1.000-11.5 NPSM	.870 (22.1)
06	1.250-11.5 NPSM	.870 (22.1)
07	1.500-11.5 NPSM	1.000 (25.4)
08	2.000-11.5 NPSM	1.190 (30.2)
09	2.500-8 NPSM	1.620 (41.1)
10	3.000-8 NPSM	1.690 (42.9)