

A

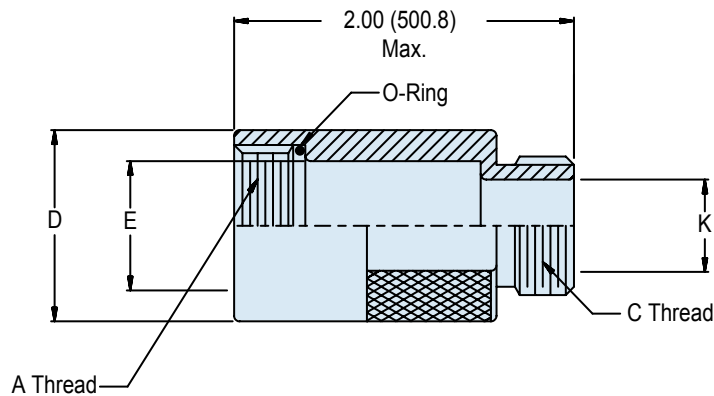
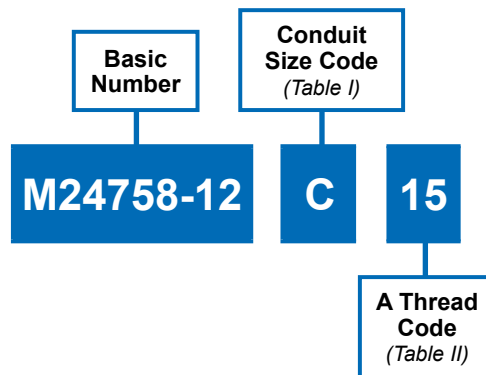

APPLICATION NOTES

1. Assembly identified with manufacturer's code identification number (Glenair, part number and classification code 490).
2. The M24758-12 adapter couples MIL-C-26482 series I connectors (series MS3100, MS3111 or MS3116) to M24758-2, M24758-3 or M24758-4 series fittings.
3. For MIL-DTL-26482 series II, the M24758-13 adapter shall be used.
4. See Glenair Circular Connector Accessories catalog for recommended torque values, Group 1.
5. Material / Finish:
Adapter - 316 / electroless nickel, matte finish.
6. Metric dimensions (mm) are indicated in parentheses.
7. See M24758-2, -3, -4 torque values for C thread.

MIL-PRF-24758-12
Adapter for MIL-C-26482
Solder Type Series I Connectors



MIL-PRF
24758A

A

TABLE I		
CONDUIT SIZE CODE	C CLASS - 2A THREAD	K DIA MIN
A	.438-28 UNEF	.245 (6.22)
B	.688-24 UNEF	.495 (12.57)
C	.938-20 UNEF	.745 (18.92)
D	1.250-18 UNEF	.995 (25.27)
E	1.563-18 UNEF	1.245 (31.62)
F	1.875-16 UN	1.495 (37.97)
G	2.375-16 UN	1.995 (50.67)
H	2.875-16 UN	2.495 (63.37)
J	.563-24 UNEF	.370 (9.340)
K	.813-20 UNEF	.620 (15.75)
L	3.375-16 UN	2.995 (76.07)

TABLE II: A-THREAD CODE AND ADAPTER DIMENSIONS				
A THREAD CODE	CONN SHELL SIZE	A CLASS - 2B THREAD	D DIA ± .02 (.51)	E DIA ± .02 (.51)
07	8	.438-28 UNEF	.590 (14.99)	.340 (8.64)
09	10	.563-24 UNEF	.710 (18.03)	.450 (11.43)
11	12	.688-24 UNEF	.840 (21.34)	.580 (14.73)
13	14	.813-20 UNEF	.960 (24.38)	.680 (17.27)
15	16	.938-20 UNEF	1.090 (27.69)	.810 (20.57)
17	18	1.063-18 UNEF	1.210 (30.73)	.930 (23.62)
19	20	1.188-18 UNEF	1.340 (34.04)	1.060 (26.92)
21	22	1.313-18 UNEF	1.460 (37.08)	1.180 (29.97)
23	24	1.438-18 UNEF	1.590 (40.39)	1.310 (33.27)