

A

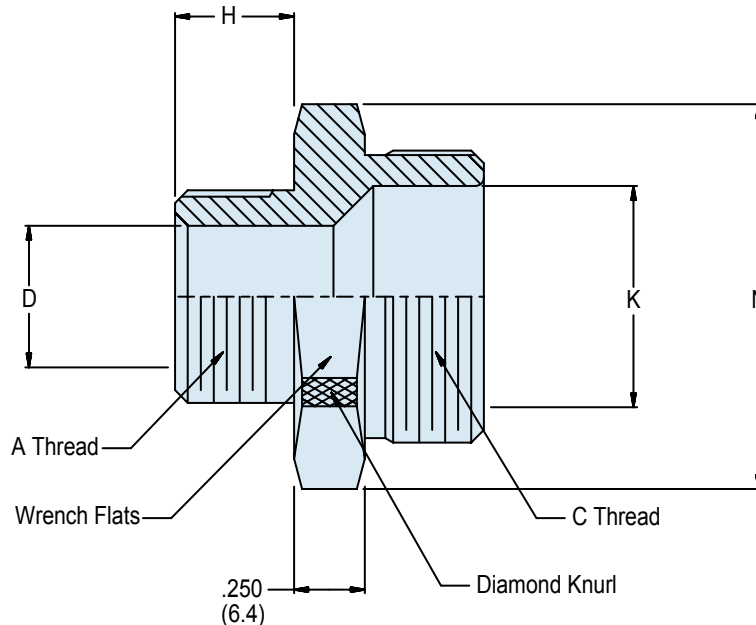
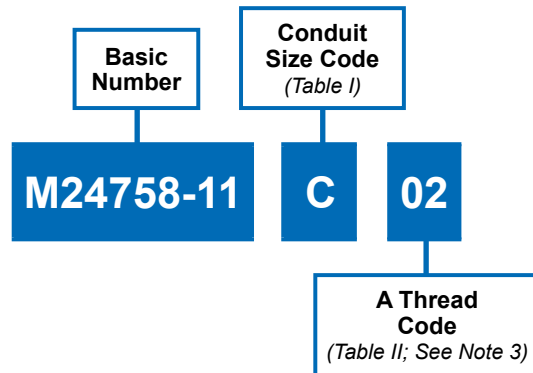

APPLICATION NOTES

1. Assembly identified with manufacturer's code identification number (Glenair, part number and classification code 490).
2. The M24758-11 adapter couples coaxial connectors to M24758-2, M24758-3, M24758-4 series fittings.
3. Select an A-thread from table II which matches that of the back of the nut on the connector being used. If none of the A-threads match, substitute the desired A-thread information in lieu of the A-thread code in the part number. For example: A fitting for a 0.500" conduit with a 0.5-28 A-thread of 0.313' H-length would have the part number: M24758-11B0.5-28-0.313.
5. Material / Finish:
Adapter - 316 / electroless nickel, matte finish
6. Metric dimensions (mm) are indicated in parentheses.
7. See M24758-2, -3, -4 torque values for C thread.

TABLE I			
CONDUIT SIZE CODE	C CLASS - 2A THREAD	K DIA MIN	N DIA ± .02 (0.5)
A	.438-28 UNEF	.245 (6.22)	.687 (17.4)
B	.688-24 UNEF	.495 (12.57)	.937 (23.8)
C	.938-20 UNEF	.745 (18.92)	1.187 (30.1)
D	1.250-18 UNEF	.995 (25.27)	1.500 (38.1)
E	1.563-18 UNEF	1.245 (31.62)	1.812 (46.0)
J	.563-24 UNEF	.370 (9.40)	.812 (20.6)
K	.813-20 UNEF	.620 (15.75)	1.062 (27.0)

TABLE II: A-THREAD CODE AND ADAPTER DIMENSIONS					
A THREAD CODE	A THREAD Class 2A	H ± .03 (.76)	D DIA ±.02 (.51)	CABLE (REFERENCE)	
				TYPE	OD
02	.375-32 UNEF	.210 (5.33)	.226 (5.74)	RG-58, RG-233	.195 (4.95) .216 (54.86)
04	.438-28 UNEF	.250 (6.35)	.345 (8.76)	RG-5, RG-21	.332 (8.43)
06	.625-24 UNEF	.310 (7.87)	.433 (10.83)	RG-9, RG-214	.420 (10.67) .425 (10.80)
08	.688-24 UNEF	.310 (7.87)	.568 (14.43)	RG-14, RG-293	.545 (13.84)
10	.938-20 UNEF	.310 (7.87)	.650 (16.51)	RG-57, RG-294	.625 (15.88) .630 (16.00)
12	.813-20 UNEF	.310 (7.87)	.895 (22.73)	RG-17	.870 (22.10)