

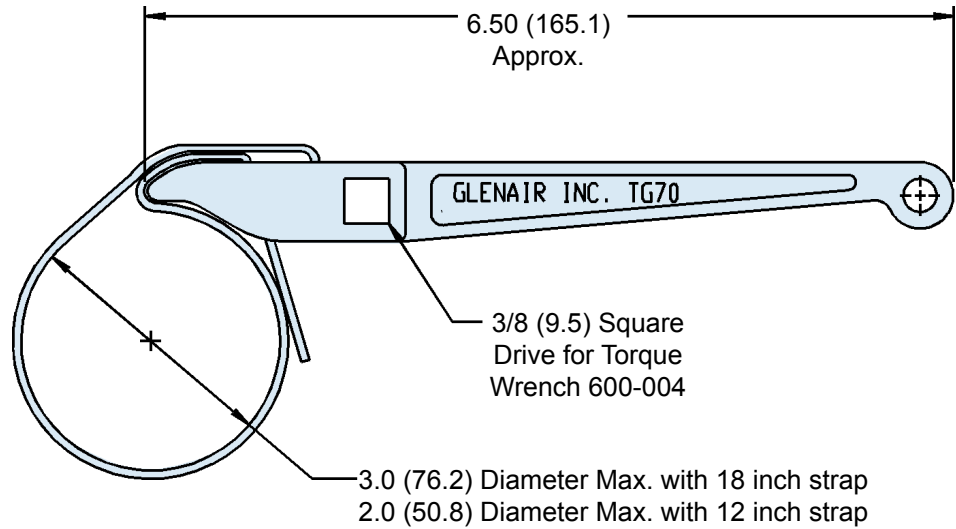

# TG70 Connector Strap Wrench With 3/8" Square Drive



<b>Basic Part No.</b>	<b>Torque Wrench</b> (Omit for None)
TG70	1 - 18
<b>Strap Length in Inches</b> Available in 12 and 18 inches <i>Omit for Standard of 12.0 Inches (304.8)</i>	

- NOTES:**
- These wrenches are made of the following materials:  
 Wrench Handle - Aluminum Alloy/Nickel Plate  
 Wedge - Stainless Steel/Passivated  
 Strap - Impregnated Fabric
  - Replacement straps are available. Specify part number G70515 for 12 inch strap or part number G70515-18 for 18 inch strap.
  - Metric dimensions (mm) are indicated in parentheses.

VARIANCE CHART				
TG-70 Strap Wrench Used with Glenair Torque Wrenches				
Accessory Shell Size	Recommended Installation Torque			
	Light/Medium Duty ± 5 Inch Pounds		Heavy Duty ± 5 Inch Pounds	
	TG70 Torque	Part Torque	TG70 Torque	Part Torque
08/09	28	35	45	60
10/11	28	35	70	80
12/13	30	40	75	110 [80]
14/15	30	40	75	120 [80]
16/17	30	40	75	120 [80]
18/19	30	40	75	120 [80]
20/21	75	80	95	140 [100]
22/23	75	80	120*	140
24/25	75	80	120*	140
28			135*	150
32			150*	150
36			150*	150

\* TG70 Not Recommended For Values of 120 Inch Lbs. or Greater.

- VARIANCE CHART NOTES:**
- Recommended installation torque is approximately 80% of MIL-C-85049 accessory thread strength values.
  - Heavy duty installation torque values may be difficult to attain with the TG70 Strap Wrench; the values shown in brackets [ ] are the maximum attainable with the TG70 Strap Wrench. Glenair recommends using 600 series torque tools whenever possible when torque loading exceeds 75 inch pounds, or to attain the heavy duty torque values shown.

