

# The Right Feed-Through Fitting for Every Shipboard Application—in Aluminum, Titanium, Composite Thermoplastic or Stainless Steel

Glenair manufactures a full spectrum line of feed-through fittings for routing wire and cable into and out of switchgear and other types of junction boxes. The fittings are also ideal for thru-panel and bulkhead applications.

From environmental sealers and EMI/RFI shield terminators to strain reliefs and shrink boot

adapters—Glenair has the right feed-through for every application requirement. Our composite thermoplastic designs offer significant weight savings and unlimited corrosion protection.

Best of all, many of our most popular part numbers are in stock, in quantity and ready for immediate delivery.

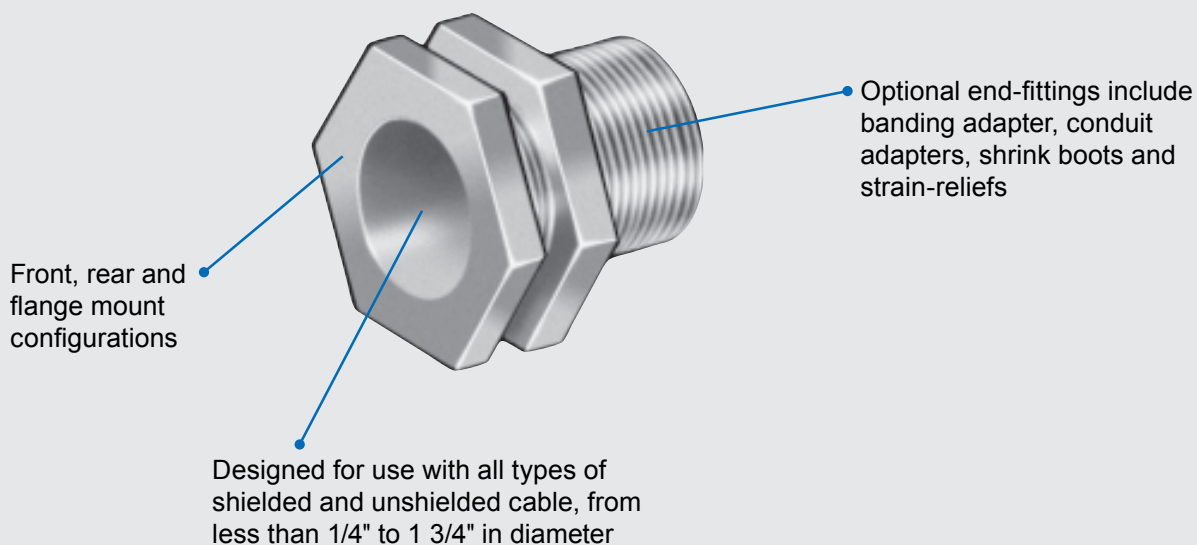

**\*Composite Thermoplastic Parts:** Unless otherwise specified, feed-through fittings will be finished per Table II. Consult factory for additional options for plating of composite components. Composite feed-throughs should be considered for applications where weight savings and extended corrosion protection is desired. Compared to aluminum alloy, composite materials provide equal or improved RFI/EMI protection; however, composite materials have lower thermal conductivity and reduced high-current grounding characteristics. Composite feed-throughs are designed to meet RTCA/DO-160C environmental conditions and physical strength requirements. Please consult the factory for assistance in selecting the best materials and platings for your application.