

*(for styles A, B and C only)

Type B Environmental Style 2

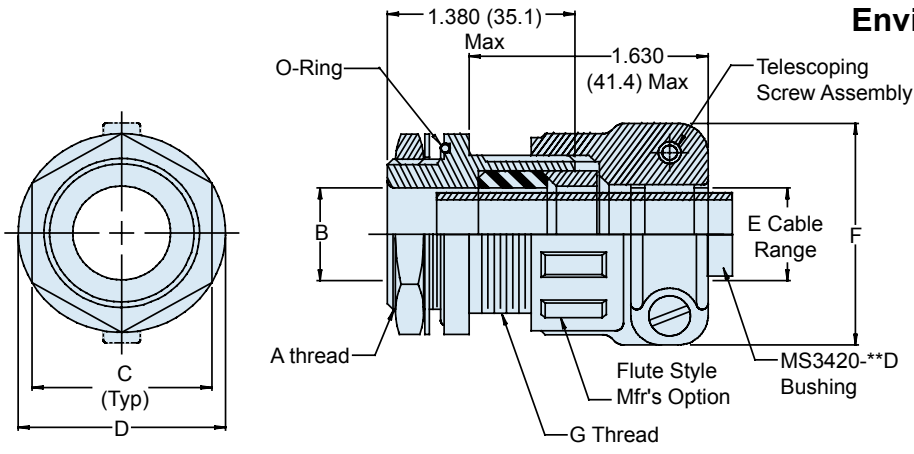

Type B Environmental Conduit Adapter Style 6 or 7

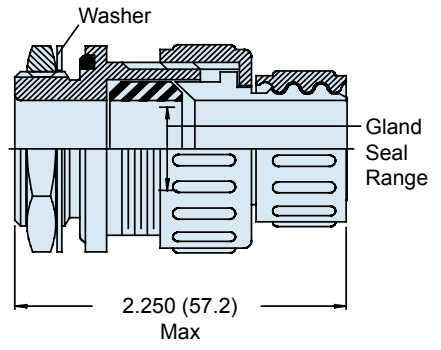

Type B RFI/EMI & Environmental Style 3

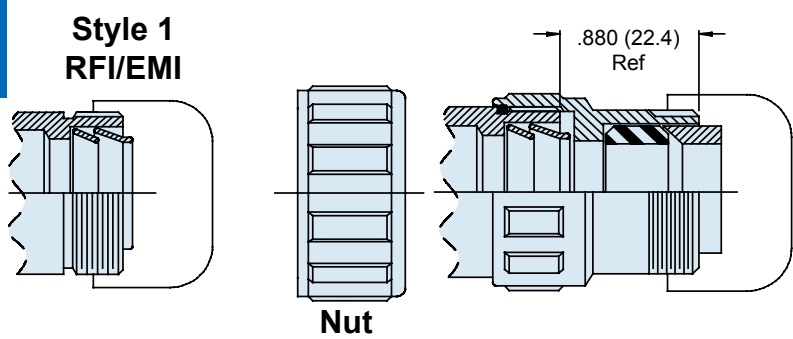

Type B Conduit Adapter Style 5

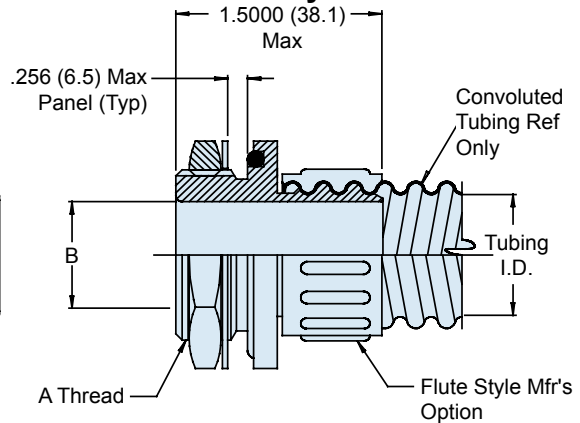

F

637-094
Composite Box Conduit or Cable
Feed-Through Adapter Series



TABLE I: BULKHEAD THREAD SIZE

Dash No.	A Thread ISO Metric	B Ref Diameter	C	D Max Diameter	Max Entry Table II
01	M16 x 1.5-6g	.55 (14.0)	.875 (22.2)	1.06 (27.2)	06
02	M20 x 1.5-6g	.61 (15.5)	1.062 (27.0)	1.19 (30.5)	10
03	M27 x 2.0-6g	.86 (21.8)	1.375 (34.9)	1.50 (38.4)	16
04	M36 x 2.0-6g	1.21 (30.7)	1.750 (44.5)	2.00 (51.1)	20
05	1 -20 UNEF-2A	.78 (19.8)	1.250 (31.8)	1.38 (35.3)	12

TABLE II: CONNECTOR SHELL SIZE ORDER NUMBER

Dash No.	E		F Max	G Thread		Ref. Conduit Size Styles 5, 6 & 7
	Min	Max		Unified Class 2A	MS3420-**D	
04	.188 (4.8)	.312 (7.9)	1.150 (29.2)	11/16-24	-04	14
06	.291 (7.1)	.438 (11.1)	1.270 (32.3)	13/16-20	-06	16
10	.375 (9.5)	.610 (15.5)	1.460 (37.1)	1 1/16-18	-06 & -10	24
12	.438 (11.1)	.750 (19.1)	1.620 (41.1)	1 1/4-18	-08 & -12	28
16	.625 (15.9)	.860 (21.8)	1.770 (44.9)	1 1/2-18	-12 & -16	32
20	.875 (22.2)	1.210 (30.7)	2.060 (52.3)	1 13/16-16	-16 & -20	40

TABLE III

Symbol	Finish Description
XB	No Plating - Black Color (Non-Conductive Finish)
XM	2000 Hour Corrosion Resistant Electroless Nickel
XMT	2000 Hour Corrosion Resistant Ni-PTFE, Nickel-Fluorocarbon Polymer. <i>1000 Hour Grey™</i>
XO	No Plating - Brown Color (Non-Conductive Finish)
XW	2000 Hour Corrosion Resistant Cadmium/Olive Drab over Electroless Nickel