

# 630-062 Composite Shrink Boot Feed-Through Adapter Jam Nut Mount Environmental

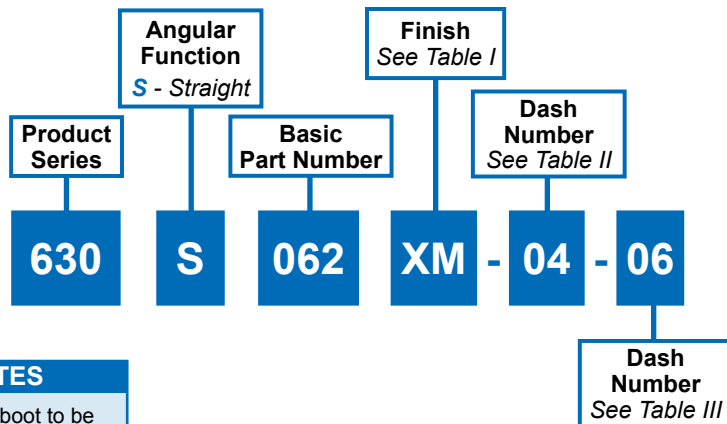

**APPLICATION NOTES**

1. Consult factory for shrink boot to be supplied with product.
2. Metric dimensions (mm) are indicated in parentheses.

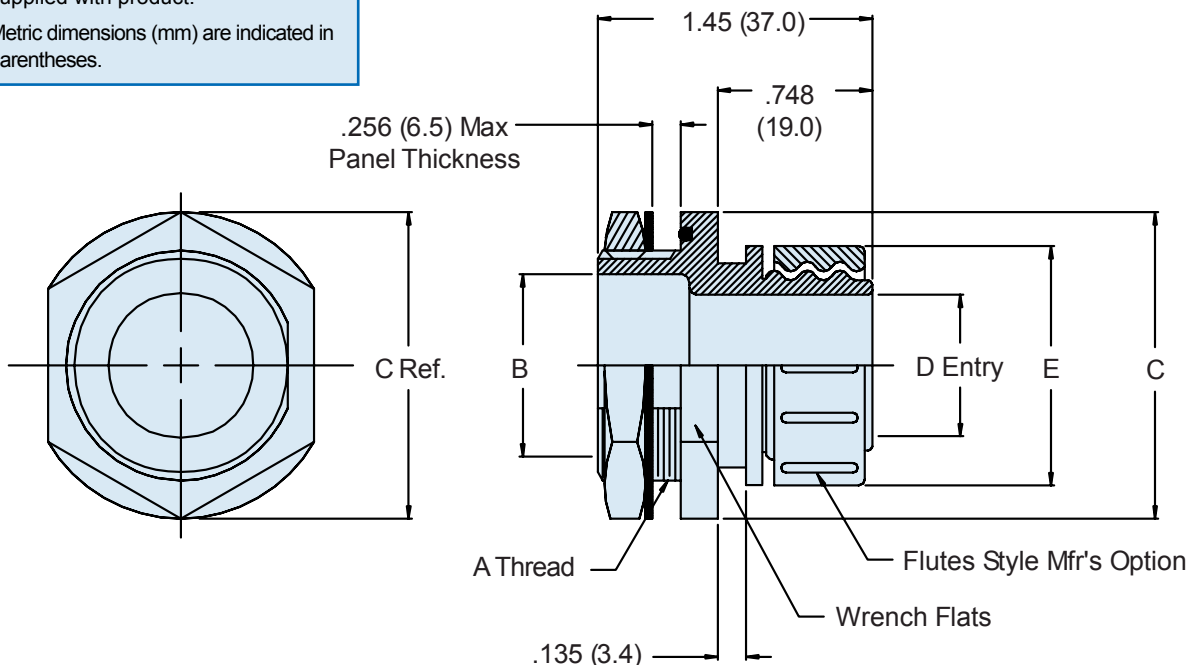

**TABLE I: Finish**

XM	Electroless Nickel
XW	Cadmium Olive Drab Over Electroless Nickel

**TABLE II: Dash Number, Max Entry**

Dash No.	A Thread ISO Metric	B Dia. Min.	C Max.	Max Entry Table III
01	M 16 x 1.5-6g	.394 (10.0)	1.024 (26.0)	03
02	M 20 x 1.5-6g	.551 (14.0)	1.181 (30.0)	04
03	M 27 x 2.0-6g	.866 (22.0)	1.496 (38.0)	07
04	M 36 x 2.0-6g	1.181 (30.0)	1.850 (47.0)	08

**TABLE III: Dash Number**

Dash No.	D		E Max.
	+ .03	(.8)	
01	.125 (3.2)	.531 (13.5)	
02	.250 (6.4)	.656 (16.7)	
03	.375 (9.5)	.781 (19.8)	
04	.500 (12.7)	.906 (23.0)	
05	.625 (15.9)	1.031 (26.2)	
06	.750 (19.1)	1.156 (29.4)	
07	.875 (22.2)	1.281 (32.5)	
08	1.000 (25.4)	1.406 (35.7)	

