

F

**TABLE I: Dash Number and Dimensions**

Dash No.	A Thread Class 2A	B Max	C +.010 (0.25) -0	D +.010 (0.25) -0	E +.010 (0.25) -0	F	G Max	H Min	Max Cable Entry	MIL-I-23053 Shrink Sleeve	MIL-I-23053 Shrink Sleeve	Braid Sock 103-005-005 Ref
01	3/4-20 UNEF	1.140 (29.0)	.340 (8.6)	.755 (19.2)	.691 (17.6)	.938 (23.8)	1.004 (25.5)	6.0	.335 (8.5)	/4-204-0	/5-109-0	A10
02	3/4-20 UNEF	1.140 (29.0)	.460 (11.7)	.755 (19.2)	.691 (17.6)	.938 (23.8)	1.132 (28.8)	6.0	.455 (11.6)	/4-204-0	/5-109-0	A10
03	7/8-20 UNEF	1.280 (32.5)	.630 (16.0)	.880 (22.4)	.816 (20.7)	1.062 (27.0)	1.343 (34.1)	6.0	.625 (15.9)	/4-205-0	/5-110-0	A10
04	1 1/16-18 UNEF	1.490 (37.8)	.755 (19.2)	1.067 (27.1)	1.004 (25.5)	1.250 (31.8)	1.468 (37.3)	6.0	.750 (19.1)	/4-206-0	/5-110-0	A14
05	1 3/16-18 UNEF	1.640 (41.7)	.880 (22.4)	1.192 (30.3)	1.130 (28.7)	1.375 (34.9)	1.593 (40.5)	6.0	.875 (22.2)	/4-506-0	/5-111-0	A16
06	1 5/16-18 UNEF	1.930 (49.0)	1.005 (25.5)	1.137 (28.9)	1.254 (31.9)	1.625 (41.3)	1.656 (42.1)	6.0	1.000 (25.4)	/4-305-0	/5-111-0	A18

630-015  
**Fiber Optic Bulkhead Feed-Through Adapter  
 Cable with Kevlar**

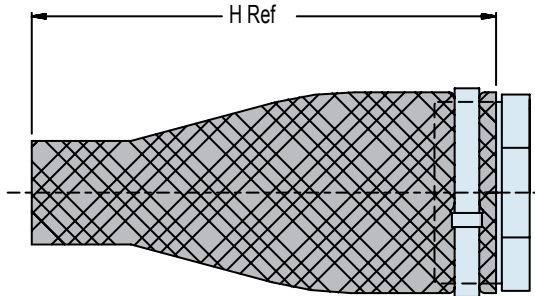

**447-822\*\*\* ASSEMBLY**  
 Style T see P/N Development

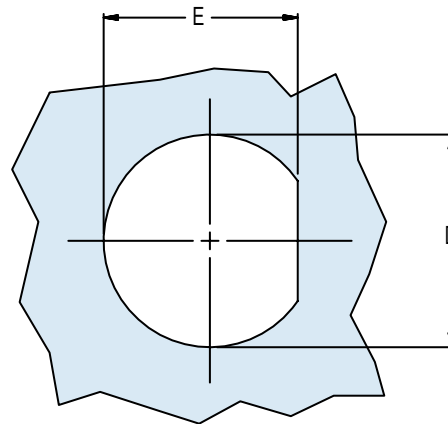

**RECOMMENDED PANEL CUT-OUT**

TABLE I: Finish	
Symbol	Description
B	Cadmium Plate/Olive Drab
M	Electroless Nickel
N	Cadmium Plate/Olive Drab over Nickel
NF	Cad/O.D. over Electroless Nickel (1,000 Hr. Salt Spray)

**APPLICATION NOTES**

1. Assembly identified with manufacturer's code identification number (Glenair, part number and classification code 490).
2. Glenair series 600 backshell assembly tools are recommended for assembly and installation.
3. Material / Finish:  
 Adapters, Jam Nut, Ferrule, Coupling Nut - Al alloy/see Table I.  
 Hardware - 316 SST/passivate.  
 Seals and gaskets - Silicone/N.A.  
 Mounting Plate - 300 series SST/passivate.
4. MIL-T-23053/4 & /5 shrink sleeving to be packaged loose in a plastic bag.
5. Metric dimensions (mm) are indicated in parentheses.

