

Style 1
Rear Mount Type A
RFI/EMI
(Shown With Style F
Strain Relief)

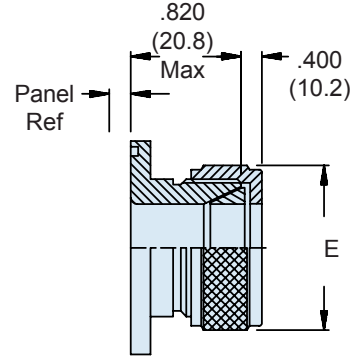

Style 1
Front Mount Type B
RFI/EMI
(Shown With Style G
Gland Nut)

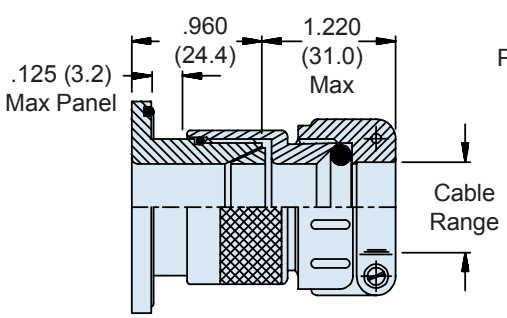
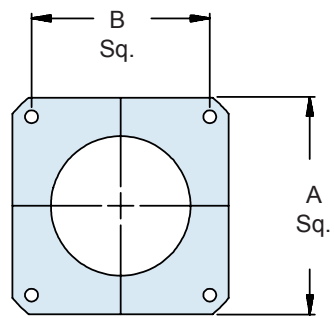

Style 2
Rear Mount Type A
RFI/EMI Environmental
(Shown With Style F
Strain Relief)

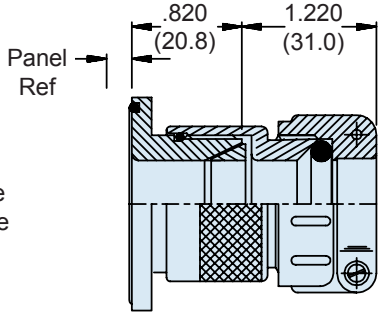

Style 2
Front Mount Type A
RFI/EMI Environmental
(Shown With Style F
Strain Relief)

F

630-008
Square Flange Feed-Through Fittings
RFI/EMI Environmental



TABLE III: Dash Number, Cable Range and Dimensions (Continued Below)

Dash No.	Cable Range		A Max	B Dim	C	
	Min	Max			+0.015 (-0)	+0.4 (-0.0)
01	.125 (3.2)	.250 (6.4)	.885 (22.5)	.593 (15.1)	.120 (3.0)	(3.0)
02	.156 (4.0)	.375 (9.5)	1.104 (28.0)	.812 (20.6)	.120 (3.0)	(3.0)
03	.250 (6.4)	.438 (11.1)	1.197 (30.4)	.906 (23.0)	.120 (3.0)	(3.0)
04	.280 (7.1)	.500 (12.7)	1.291 (32.8)	.968 (24.6)	.120 (3.0)	(3.0)
05	.375 (9.5)	.625 (15.9)	1.385 (35.2)	1.062 (27.0)	.120 (3.0)	(3.0)
06	.500 (12.7)	.750 (19.1)	1.635 (41.5)	1.250 (31.8)	.120 (3.0)	(3.0)
07	.625 (15.9)	.875 (22.2)	1.760 (44.7)	1.375 (34.9)	.147 (3.7)	(3.7)
08	.750 (19.1)	1.000 (25.4)	2.010 (51.1)	1.562 (39.7)	.147 (3.7)	(3.7)
09	.875 (22.2)	1.125 (28.6)	2.260 (57.4)	1.750 (44.5)	.173 (4.4)	(4.4)
10	1.000 (25.4)	1.250 (31.8)	2.510 (63.8)	1.938 (49.2)	.173 (4.4)	(4.4)

TABLE III: (Continued from Above)

Dash No.	D Max	E Max	F		G	
			+0.015 (-0)	+0.4 (-0.0)	+0.031 (-0)	+0.8 (-0.0)
01	.843 (21.4)	.625 (15.9)	.515 (13.1)	(13.1)	.250 (6.4)	(6.4)
02	.968 (24.6)	.750 (19.1)	.640 (16.3)	(16.3)	.375 (9.5)	(9.5)
03	1.046 (26.6)	.875 (22.2)	.765 (19.4)	(19.4)	.438 (11.1)	(11.1)
04	1.156 (29.4)	1.000 (25.4)	.890 (22.6)	(22.6)	.500 (12.7)	(12.7)
05	1.218 (30.9)	1.125 (28.6)	1.015 (25.8)	(25.8)	.625 (15.9)	(15.9)
06	1.343 (34.1)	1.250 (31.8)	1.140 (29.0)	(29.0)	.750 (19.1)	(19.1)
07	1.468 (37.3)	1.375 (34.9)	1.265 (32.1)	(32.1)	.875 (22.2)	(22.2)
08	1.593 (40.5)	1.500 (38.1)	1.390 (35.3)	(35.3)	1.000 (25.4)	(25.4)
09	1.718 (43.6)	1.625 (41.3)	1.515 (38.5)	(38.5)	1.125 (28.6)	(28.6)
10	1.843 (46.8)	1.750 (44.5)	1.640 (41.7)	(41.7)	1.250 (31.8)	(31.8)

APPLICATION NOTES

1. Assembly identified with manufacturer's name and part number, space permitting.
2. Cable range is defined as the accommodations range for the wire bundle or cable. Dimensions shown are not intended for inspection criteria.
3. Material / Finish: See Table II.
4. Metric dimensions (mm) are indicated in parentheses.