



# Entraco to Glenair

## MIL-PRF-24758A

### Cross Reference

# Entraco to Glenair Cross Reference

## CONDUIT

ENTRACO PART NUMBER
CC 249 - XX
CC 261 - XX

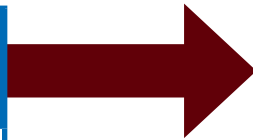

ENTRACO PART NUMBER (1/32 In. Increments)	DECIMAL ID (Inch)	CONDUIT SIZE
8	0.250	A
12	0.375	J
16	0.500	B
20	0.625	K
24	0.750	C
28	0.875	N/C
32	1.000	D
40	1.250	E
48	1.500	F
64	2.000	G
N/C	2.500	H
N/C	3.000	L

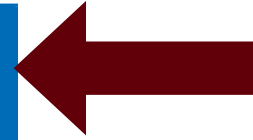

GLENAIR PART NUMBER
M24758-X

### CONDUIT SPLICE: M24758-24X

**NOTE:** Requires 2 each M24758-2 Series Conduit Fittings and one M24758-24 Series Adapter.

# Entraco to Glenair Cross Reference

## STUFFING TUBE

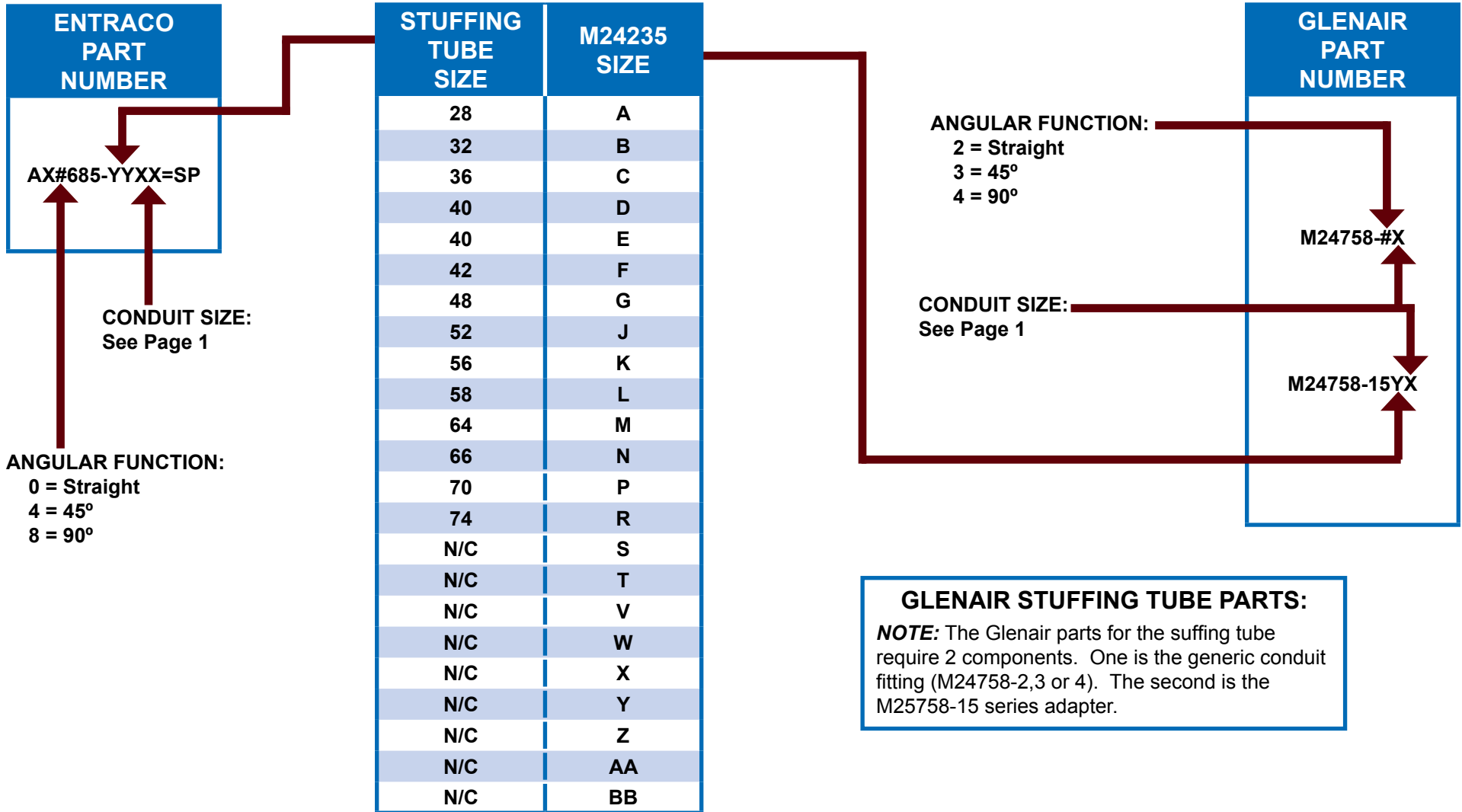

# Entraco to Glenair Cross Reference

## PIPE THREAD

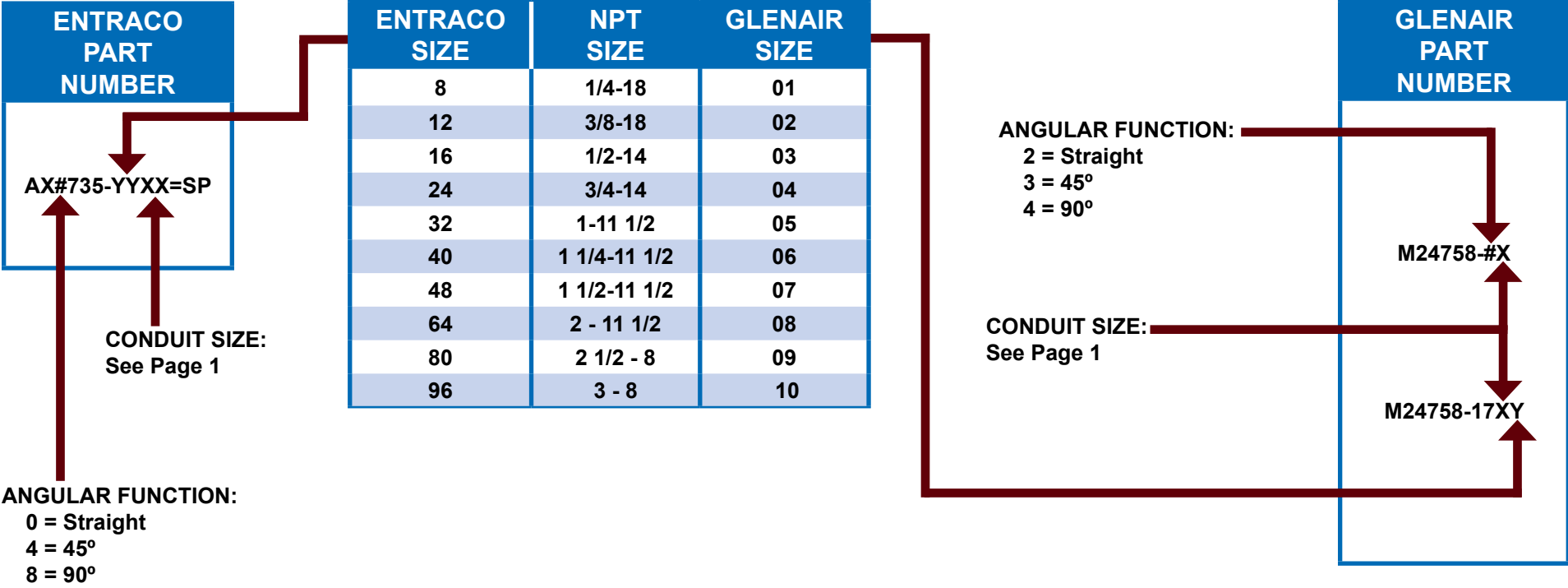

**GLENAIR NPT FITTING PARTS:**

**NOTE:** The Glenair parts for the NPT fitting require 2 components. One is the generic conduit fitting (M24758-2, 3 or 4). The second is the M24758-17 series adapter.

# Entraco to Glenair Cross Reference

## PANEL FITTING (BOX HUB)

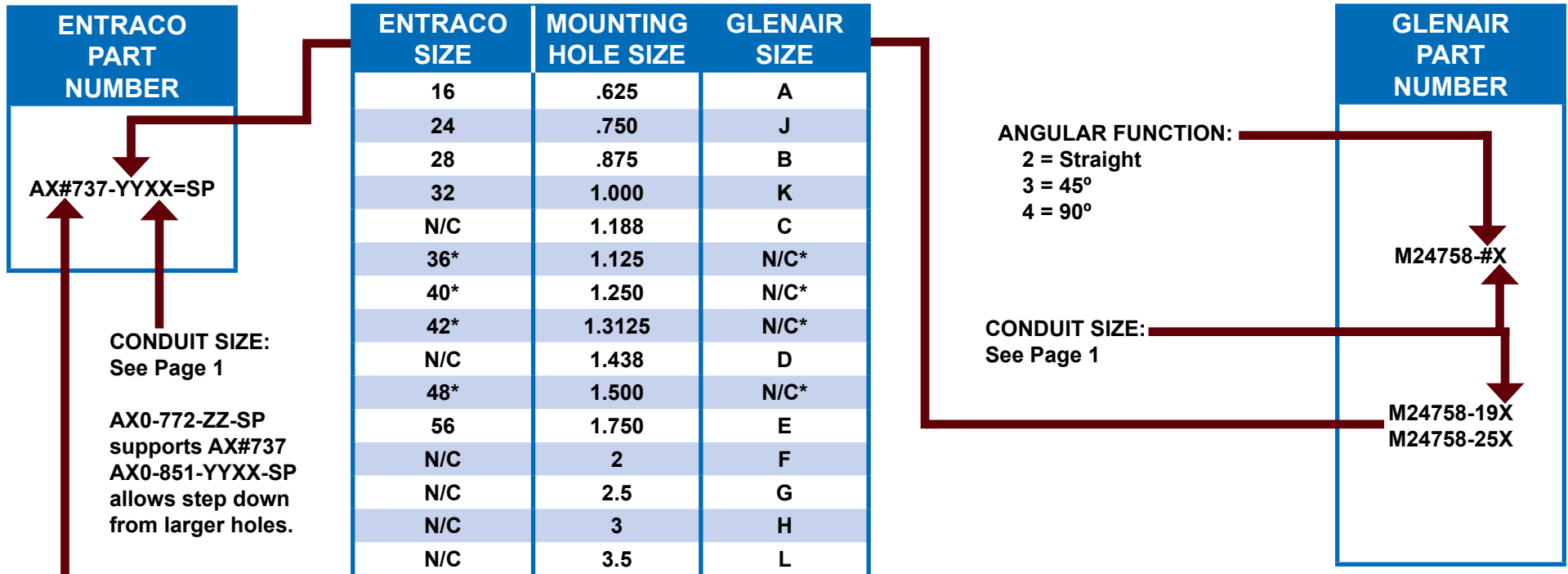

**ENTRACO PART NUMBER**

AX#737-YYXX=SP

ENTRACO SIZE	MOUNTING HOLE SIZE	GLENAIR SIZE
16	.625	A
24	.750	J
28	.875	B
32	1.000	K
N/C	1.188	C
36*	1.125	N/C*
40*	1.250	N/C*
42*	1.3125	N/C*
N/C	1.438	D
48*	1.500	N/C*
56	1.750	E
N/C	2	F
N/C	2.5	G
N/C	3	H
N/C	3.5	L

**GLENAIR PART NUMBER**

M24758-#X

M24758-19X  
M24758-25X

**CONDUIT SIZE:**  
See Page 1

AX0-772-ZZ-SP supports AX#737  
AX0-851-YYXX-SP allows step down from larger holes.

**ANGULAR FUNCTION:**  
2 = Straight  
3 = 45°  
4 = 90°

**CONDUIT SIZE:**  
See Page 1

**ANGULAR FUNCTION:**  
0 = Straight  
4 = 45°  
8 = 90°

\*For existing applications where panel hole is drilled for Entraco fitting use M24758-26X instead of -19 or -25.

**GLENAIR PANEL PARTS:**

**NOTE:** The Glenair parts for the panel require 2 components. One is the generic conduit fitting (M24758-2,3 or 4). The second is either the M24758-19 series adapter (internal jam nut), or M24758-25 series adapter (external jam nut).

# Entraco to Glenair Cross Reference

## CIRCULAR CONNECTOR

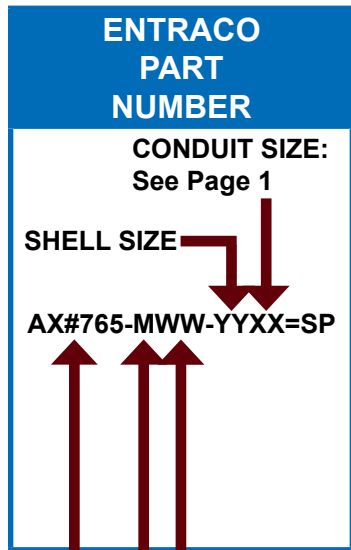

MISTY FUNCTION

ANGULAR FUNCTION:  
0 = Straight  
4 = 45°  
8 = 90°

ENTRACO DESIGNATOR	CONNECTOR TYPE	GLENAIR CONNECTOR ADAPTER
21	M26482 Series I	M24758-12
30	M28840	M24758-14
32	M22992	M24758-21
40	M38999 Series III/IV	M24758-20
41	M38999 Series I/II	M24758-20
51	M26500	N/C
52	M26500	N/C
54	M5015 (Crimp)	M24758-13
N/C	M5015 (Solder)	M24758-9
N/C	COAX	M24758-11
N/C	Glenair Series 22	M24758-22
61	M81511	N/C

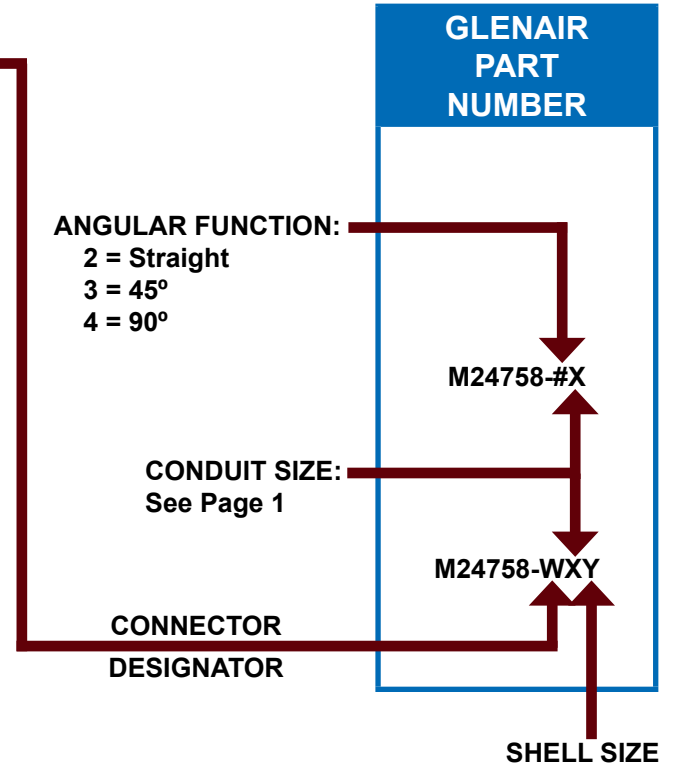

**GLENAIR CONNECTOR PARTS:**

**NOTE:** The Glenair parts for the connector require 2 components. One is the generic conduit fitting (M24758-2,3 or 4). The second is the connector series adapter.