

# GA/CSGA-\*/NPT-49B

## Male Pipe Thread

### Stainless Steel Cable Shield Grounding Assembly

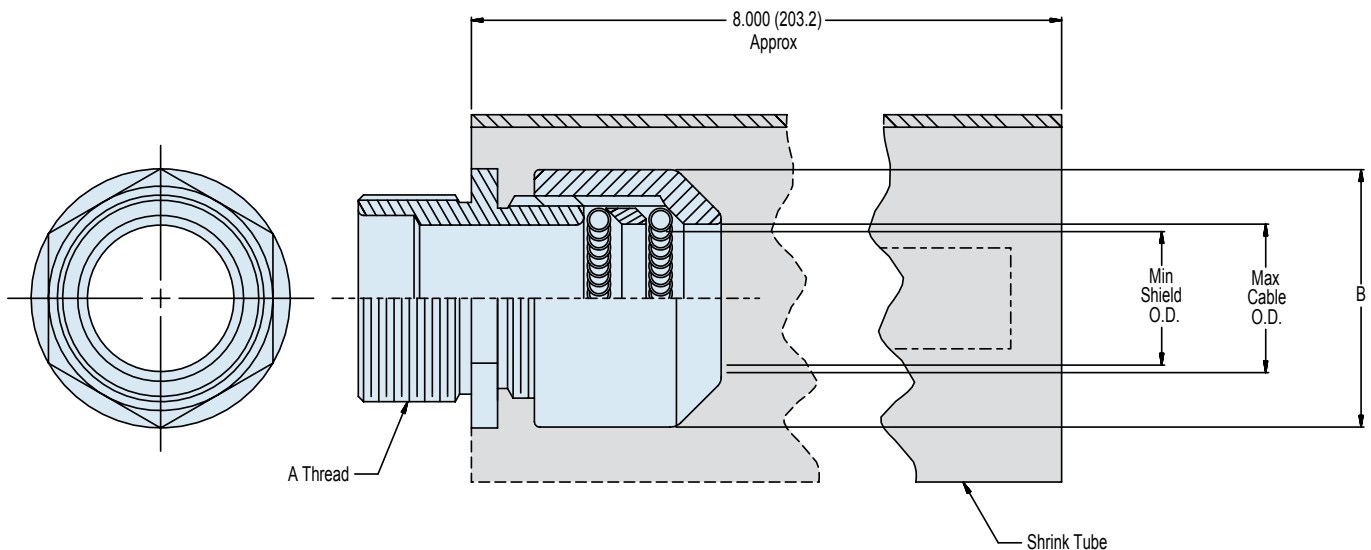
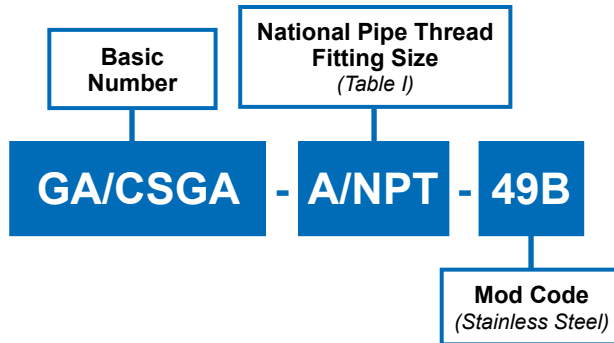

#### APPLICATION NOTES

1. Assembly identified with manufacturer's code identification number (Glenair, part number and classification code 490).
2. Glenair series 600 backshell assembly tools are recommended for assembly and installation.
3. Material / Finish:
  - Adapters - CRES/passivate.
  - Ferrule, grounding spring - CRES/passivate.
  - Tubing - Heat shrinkable, flame retardant, with adhesive.
4. Metric dimensions (mm) are indicated in parentheses.

**GA/CSGA-\*/NPT-49B**  
**Male Pipe Thread**  
**Stainless Steel Cable Shield Grounding Assembly**



CSGA

**TABLE I: Stuffing Tube Size and Adapter Dimensions**

Glenair Part No.	A Thread	Max Cable O.D.	Min Shield O.D.	B Max	Shrink Tube Number
GA/CSGA-A/NPT-49B	3/8-18 NPT	.406 (10.3)	.200 (5.1)	1.120 (28.4)	HRSR 125
GA/CSGA-B/NPT-49B	1/2-14 NPT	.515 (13.1)	.260 (6.6)	1.120 (28.4)	
GA/CSGA-C/NPT-49B	3/4-14NPT	.640 (16.3)	.400 (10.2)	1.320 (33.5)	HRSR 175
GA/CSGA-D/NPT-49B	3/4-14 NPT	.750 (19.1)	.400 (10.2)	1.630 (41.4)	
GA/CSGA-E/NPT-49B	1-11 1/2 NPT	.812 (20.6)	.430 (10.9)	1.630 (41.4)	
GA/CSGA-F/NPT-49B	1-11 1/2 NPT	.843 (21.4)	.470 (11.9)	1.750 (44.5)	HRSR 200
GA/CSGA-G/NPT-49B	1-11 1/2 NPT	.953 (24.2)	.580 (14.7)	1.880 (47.8)	
GA/CSGA-J/NPT-49B	1 1/4-11 1/2 NPT	1.062 (27.0)	.690 (17.5)	1.880 (47.8)	
GA/CSGA-K/NPT-49B	1 1/4-11 1/2 NPT	1.172 (29.8)	.800 (20.3)	2.060 (5.2)	HRSR 250
GA/CSGA-L/NPT-49B	1 1/4-11 1/2 NPT	1.265 (32.1)	.890 (22.6)	2.180 (55.4)	
GA/CSGA-M/NPT-49B	1 1/2-11 1/2 NPT	1.406 (35.7)	1.010 (25.7)	2.320 (58.9)	
GA/CSGA-N/NPT-49B	1 1/2-11 1/2 NPT	1.515 (38.5)	1.130 (28.7)	2.380 (60.5)	
GA/CSGA-P/NPT-49B	2-11 NPT	1.625 (41.3)	1.200 (30.5)	2.440 (62.0)	HRSR 300
GA/CSGA-R/NPT-49B	2-11 NPT	1.750 (44.5)	1.250 (31.8)	2.750 (69.9)	
GA/CSGA-S/NPT-49B	2-11 NPT	1.875 (47.6)	1.380 (35.1)	2.880 (73.2)	
GA/CSGA-T/NPT-49B	2 1/2-8 NPT	2.062 (52.4)	1.560 (39.6)	3.130 (79.5)	HRSR 400
GA/CSGA-V/NPT-49B	2 1/2-8 NPT	2.187 (55.5)	1.690 (42.9)	3.250 (82.6)	

D