

**GA/CSGA
Male
Cable Shield Grounding Assembly**



CSGA

TABLE I: Stuffing Tube Size and Adapter Dimensions

Glenair Part No.	A Thread	Max Cable O.D.	Min Shield O.D.	B Max	Shrink Tube Number
GA/CSGA-A (sm)	7/8 -12 UN	.250 (6.4)	.125 (3.2)	1.120 (28.4)	HRSR 125
GA/CSGA-A	7/8 -12 UN	.406 (10.3)	.200 (5.1)	1.120 (28.4)	
GA/CSGA-B	1 -12 UN	.515 (13.1)	.260 (6.6)	1.120 (28.4)	
GA/CSGA-C	1 1/8 -12 UN	.640 (16.3)	.400 (10.2)	1.320 (33.5)	HRSR 175
GA/CSGA-D	1 1/4 -12 UN	.750 (19.1)	.400 (10.2)	1.630 (41.4)	
GA/CSGA-E	1 1/4 -12 UN	.812 (20.6)	.430 (10.9)	1.630 (41.4)	
GA/CSGA-F	1 5/16 -12 UN	.843 (21.4)	.470 (11.9)	1.750 (44.5)	HRSR 200
GA/CSGA-G	1 1/2 -12 UN	.953 (24.2)	.580 (14.7)	1.880 (47.8)	
GA/CSGA-J	1 5/8 -12 UN	1.062 (27.0)	.690 (17.5)	1.880 (47.8)	
GA/CSGA-K	1 3/4 -12 UN	1.172 (29.8)	.800 (20.3)	2.060 (5.2)	HRSR 250
GA/CSGA-L	1 13/16 -12 UN	1.265 (32.1)	.890 (22.6)	2.180 (55.4)	
GA/CSGA-M	2 -12 UN	1.406 (35.7)	1.010 (25.7)	2.320 (58.9)	
GA/CSGA-N	2 1/16 -12 UN	1.515 (38.5)	1.130 (28.7)	2.380 (60.5)	
GA/CSGA-P	2 3/16 -12 UN	1.625 (41.3)	1.200 (30.5)	2.440 (62.0)	
GA/CSGA-R	2 5/16 -12 UN	1.750 (44.5)	1.250 (31.8)	2.750 (69.9)	HRSR 300
GA/CSGA-S	2 11/16 -12 UN	1.875 (47.6)	1.380 (35.1)	2.880 (73.2)	
GA/CSGA-T	2 7/8 -12 UN	2.062 (52.4)	1.560 (39.6)	3.130 (79.5)	HRSR 400
GA/CSGA-V	3 -12 UN	2.187 (55.5)	1.690 (42.9)	3.250 (82.6)	

D

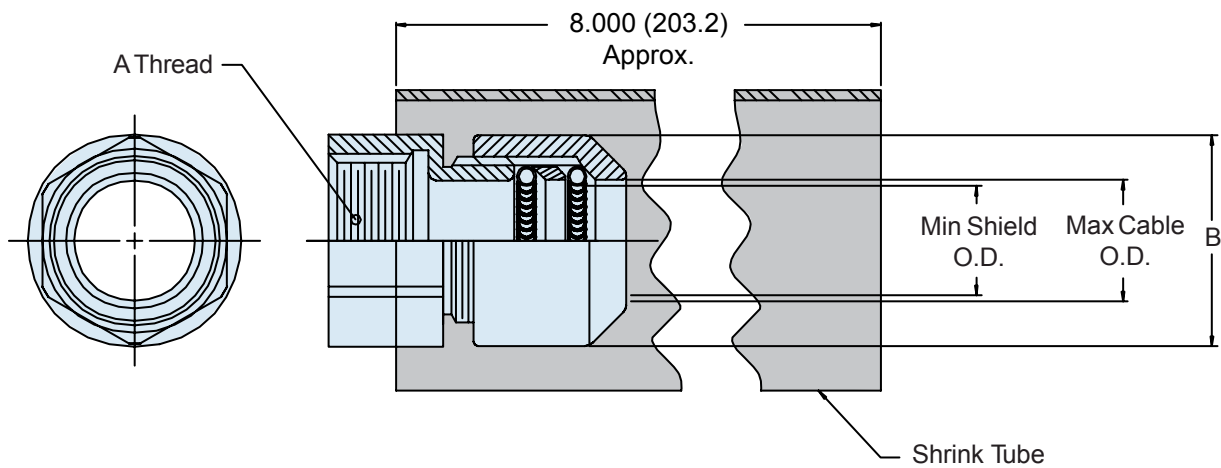
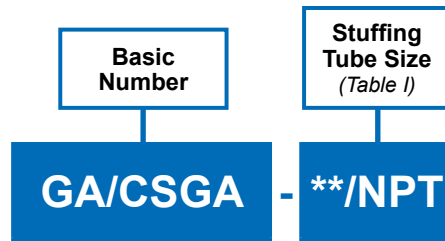

APPLICATION NOTES

1. Assembly identified with manufacturer's code identification number (Glenair, part number and classification code 490).
2. Glenair series 600 backshell assembly tools are recommended for assembly and installation.
3. Material / Finish:
Adapters - Al alloy/cad/O.D. over electroless nickel (500 hr salt spray).
Ferrule, grounding spring - CRES/passivate.
Tubing - Heat shrinkable, flame retardant, with adhesive.
4. Metric dimensions (mm) are indicated in parentheses.

*Available in Passivated 316 Stainless Steel, add 49A to end of part number.