

Basic Part Number	Finish (See Table I)	Basic Box Number
147-022	XMS - 01	01

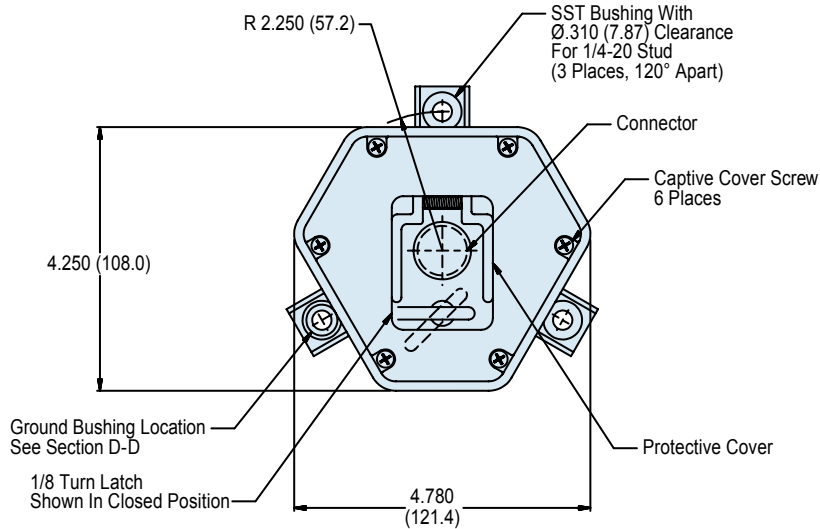
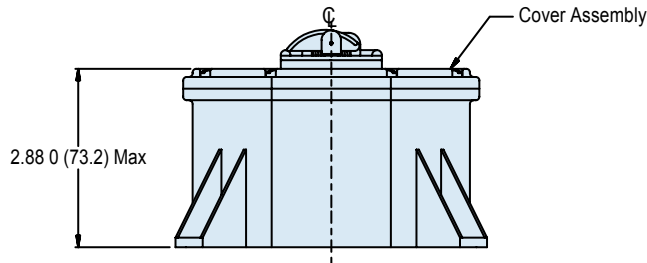

FIGURE 1 TOP VIEW



E

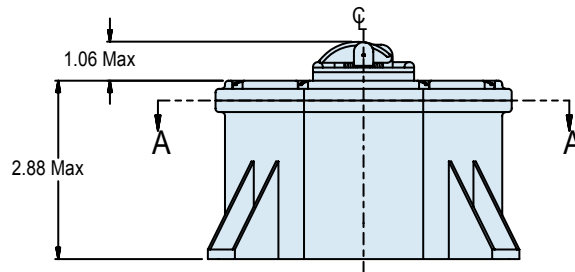
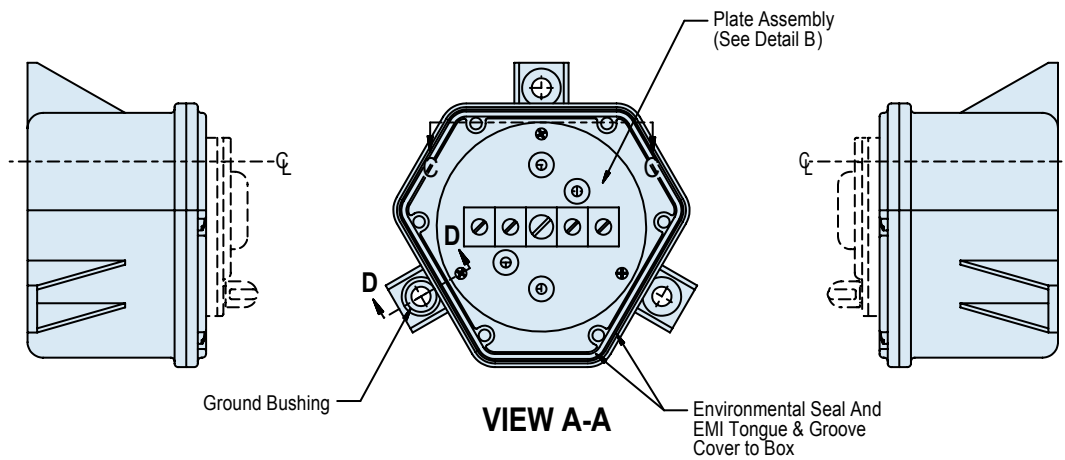
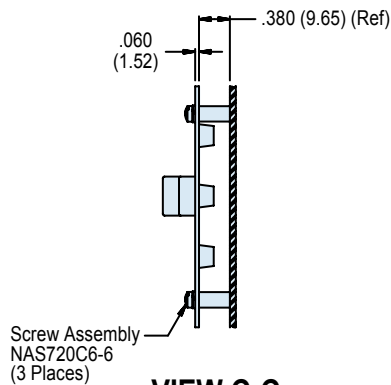
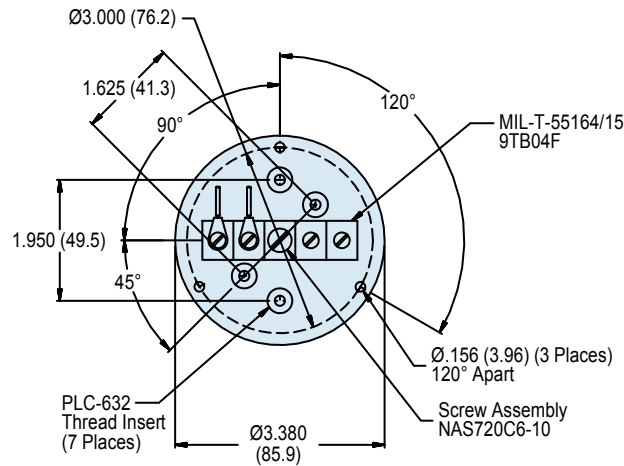

FIGURE 2





APPLICATION NOTES

1. Assembly identified with manufacturer's code identification number (Glenair, part number and classification code 490).
2. Color may be subject to fading, however UV exposure will not affect material physical properties.
3. Assembly is similar to symbol part numbers and require installation in accordance with NAVSEA drawing 803-6983506.
4. Material / Finish:
Box, cover - Thermoplastic grey color/see Table I.
Hardware - 316 SST/passivate.
Seals and gaskets - Silicone/N.A.
Mounting Plate - 300 series SST/passivate.
5. NAVSEA approved; Dwg 803-698-3506.
6. Metric dimensions (mm) are indicated in parentheses.

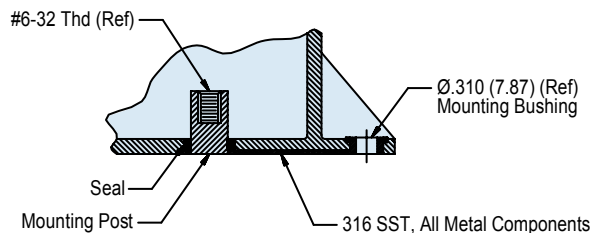

SECTION D-D
**Electrical Ground Through Internal
Mounting Post To External Mounting Bushing**

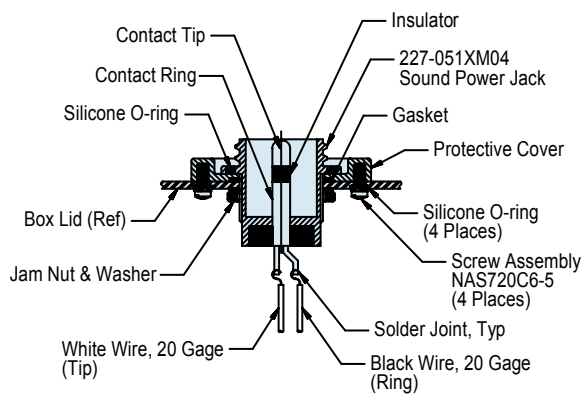

SOUND POWER JACK SECTION VIEW
(1 Place)

TABLE I: Finish	
Symbol	Description
XMS	Internal Surfaces - Electroless Nickel Exterior Surfaces - Unplated Light Grey Color
XO	No Plating

