

# Series 77 Shrink Boots Straight Lipped Adapter Boots



## Lipped Straight Shrink Boots



Straight boots with lip for attachment to standard circular connector adapters. After shrinking, the boot lip locks into adapter groove. Eyelet hole allows attachment of dust caps or protective covers. Choose Type 1 high performance elastomer for extreme temperatures and excellent resistance to fuels and oils, Type 2 non-halogenated flame-retardant polyolefin for use where limited fire hazard is required, or choose Type 3 general purpose polyolefin for use where occasional exposure to heat and chemicals may occur. Choose boot size based on adapter diameter and cable diameter.

**Table 1: Boot Size Selection Guide**

Boot Size	Adapter Diameter				Min. Cable Diameter	
	Inches		Millimeters		In.	mm.
	Min	Max	Min	Max		
00	.250	.325	6.35	8.26	.110	2.79
01	.325	.425	7.62	10.80	.150	3.81
02	.350	.600	8.89	15.24	.175	4.45
03	.450	.850	11.43	21.59	.225	5.72
04	.600	1.000	15.24	25.40	.275	6.99
05	.750	1.200	19.05	30.48	.300	7.62
06	.900	1.350	22.86	34.29	.375	9.53
07	1.250	1.650	31.75	41.91	.425	10.80
08	1.400	2.250	35.56	57.15	.625	15.88
09	1.870	2.470	47.50	62.70	.660	16.80

**Table 2: Material Selection Guide**

Attribute	Type 1 High Performance Semi-Rigid Elastomer	Type 2 Zero Halogen Semi-Rigid Polyolefin	Type 3 General Purpose Flexible Polyolefin
Continuous Operating Temp.	-75° to +150°C	-30° to +125°C	-55° to +135°C
Resistance to Fuels, Oils	Excellent	Very Good	Good
Low Toxicity, Zero Halogen	No	Yes	No

**Table 3: Pre-Coated Boots Adhesive Information**

Attribute	W2 Standard Hot Melt Adhesive	W1 High Temperature Hot Melt Adhesive	R High Performance Epoxy Adhesive
Boot Material Compatibility	Types 1, 2 and 3	Types 1, 2 and 3	Type 1
Continuous Operating Temp.	-40° to +80°C	-55° to +105°C	-75° to +150°C
Resistance to Fuels, Oils, and Fluids	Good	Good	Excellent
Low Toxicity, Zero Halogen	Yes	Yes	Yes

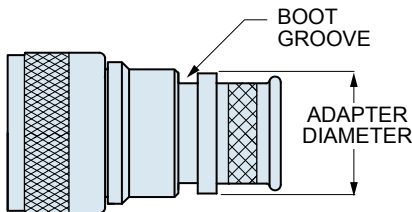

## Lipped Straight Shrink Boots- Type I High Performance Elastomer

- **-75° C to +150° C**
- **Excellent resistance to fuels, oils, solvents and heat.**

Semi-rigid high performance boots combine excellent resistance to fuels, oils and solvents with superior performance at extreme temperatures. Rated for 3000 hours continuous operation at +150° C, these boots fit most standard boot adapters for circular connectors. Material meets the requirements of VG95343 Type 6, BSG 198-5-DE, EN62329-102 and SAE AS5258 Type H. These boots are recommended for demanding applications such as military vehicles and petrochemical exploration. Choose standard length or short length if space is limited. Black color.

Boot Size	Part Number with Eyelet				Part Number without Eyelet			
	No Adhesive Lining	Pre-Coated with W1 Hi-Temp Hot-Melt Adhesive	Pre-Coated with W2 Standard Hot-Melt Adhesive	Pre-Coated with R Epoxy Adhesive	No Adhesive Lining	Pre-Coated with W1 Hi-Temp Hot-Melt Adhesive	Pre-Coated with W2 Standard Hot-Melt Adhesive	Pre-Coated with R Epoxy Adhesive
00	—	—	—	—	770-003S100	770-003S100W1	770-003S100W2	770-003S100R
01	—	—	—	—	770-003S101	770-003S101W1	770-003S101W2	770-003S101R
02	—	—	—	—	770-003S102	770-003S102W1	770-003S102W2	770-003S102R
03	770-001S103	770-001S103W1	770-001S103W2	770-001S103R	770-003S103	770-003S103W1	770-003S103W2	770-003S103R
04	770-001S104	770-001S104W1	770-001S104W2	770-001S104R	770-003S104	770-003S104W1	770-003S104W2	770-003S104R
05	770-001S105	770-001S105W1	770-001S105W2	770-001S105R	770-003S105	770-003S105W1	770-003S105W2	770-003S105R
06	770-001S106	770-001S106W1	770-001S106W2	770-001S106R	770-003S106	770-003S106W1	770-003S106W2	770-003S106R
07	770-001S107	770-001S107W1	770-001S107W2	770-001S107R	770-003S107	770-003S107W1	770-003S107W2	770-003S107R
08	770-001S108	770-001S108W1	770-001S108W2	770-001S108R	770-003S108	770-003S108W1	770-003S108W2	770-003S108R
09	770-001S109	770-001S109W1	770-001S109W2	770-001S109R	770-003S109	770-003S109W1	770-003S109W2	770-003S109R

Dimensions in inches (millimeters) and are subject to change without notice.

## Series 77 Shrink Boots Straight Lipped Adapter Boots How To Order

### Lipped Straight Shrink Boots- Type 2 Zero Halogen, Semi-Rigid

- *Low Smoke, Zero Halogen*
- *Meets U.S. and E.U. toxicity requirements.*

Halogen-free polyolefin boots meet low smoke and toxicity requirements of shipboard, transit and aircraft systems. These Low Smoke/Zero Halogen (LSZH) boots fit most standard shrink boot adapters, including M85049 types along with Glenair Series 31 and Series 44 adapters. Oxygen index greater than 30%, smoke index less than 20, and toxicity index under 3 per 100 grams. Material meets requirements of NAVSEA 5617649, VG95343 Part 29, BSG 198-5-DF, EN62329-101 and SAE AS5258 Type G. Good resistance to oils, fuels and solvents. Available high temperature hot melt adhesive lining, these boots provide strain relief and environmental protection to connector/cable transitions. Temperature rating -30° to +125° C. Black color.



Boot Size	Part Number with Eyelet			Part Number without Eyelet		
	No Adhesive Lining	Pre-Coated with W1 Hi-Temp Hot-Melt Adhesive	Pre-Coated with W2 Standard Hot-Melt Adhesive	No Adhesive Lining	Pre-Coated with W1 Hi-Temp Hot-Melt Adhesive	Pre-Coated with W2 Standard Hot-Melt Adhesive
00	—	—	—	770-003S200	770-003S200W1	770-003S200W2
01	—	—	—	770-003S201	770-003S201W1	770-003S201W2
02	—	—	—	770-003S202	770-003S202W1	770-003S202W2
03	770-001S203	770-001S203W1	770-001S203W2	770-003S203	770-003S203W1	770-003S203W2
04	770-001S204	770-001S204W1	770-001S204W2	770-003S204	770-003S204W1	770-003S204W2
05	770-001S205	770-001S205W1	770-001S205W2	770-003S205	770-003S205W1	770-003S205W2
06	770-001S206	770-001S206W1	770-001S206W2	770-003S206	770-003S206W1	770-003S206W2
07	770-001S207	770-001S207W1	770-001S207W2	770-003S207	770-003S207W1	770-003S207W2
08	770-001S208	770-001S208W1	770-001S208W2	770-003S208	770-003S208W1	770-003S208W2
09	770-001S209	770-001S209W1	770-001S209W2	770-003S209	770-003S209W1	770-003S209W2

### Lipped Straight Shrink Boots- Type 3 Polyolefin, Flexible

- *General purpose harnessing*
- *Economical, flexible*
- *-55° C to +135° C*

Economical flexible polyolefin boots fit most standard shrink boot adapters, Glenair Series 31 and Series 44 adapters. These self-extinguishing boots meet the requirements of SAE AS81765/1 Type II. Good resistance to oils and fuels. Available with optional hot melt adhesive lining, these boots provide strain relief and environmental protection to connector/cable transitions. Temperature rating -55° to +135° C. Black color.



Boot Size	Part Number with Eyelet			Part Number without Eyelet		
	No Adhesive Lining	Pre-Coated with W2 Standard Hot-Melt Adhesive	Pre-Coated with W1 Hi-Temp Hot-Melt Adhesive	No Adhesive Lining	Pre-Coated with W2 Hot-Melt Adhesive	Pre-Coated with W1 Hi-Temp Hot-Melt Adhesive
00	—	—	—	770-003S300	770-003S300W2	770-003S300W1
01	—	—	—	770-003S301	770-003S301W2	770-003S301W1
02	—	—	—	770-003S302	770-003S302W2	770-003S302W1
03	770-001S303	770-001S303W2	770-001S303W1	770-003S303	770-003S303W2	770-003S303W1
04	770-001S304	770-001S304W2	770-001S304W1	770-003S304	770-003S304W2	770-003S304W1
05	770-001S305	770-001S305W2	770-001S305W1	770-003S305	770-003S305W2	770-003S305W1
06	770-001S306	770-001S306W2	770-001S306W1	770-003S306	770-003S306W2	770-003S306W1
07	770-001S307	770-001S307W2	770-001S307W1	770-003S307	770-003S307W2	770-003S307W1
08	770-001S308	770-001S308W2	770-001S308W1	770-003S308	770-003S308W2	770-003S308W1
09	770-001S309	770-001S309W2	770-001S309W1	770-003S309	770-003S309W2	770-003S309W1

Dimensions in inches (millimeters) and are subject to change without notice.

# Series 77 Shrink Boots Straight Lipped Adapter Boots Dimensions



## Lipped Straight Shrink Boots- Dimensions

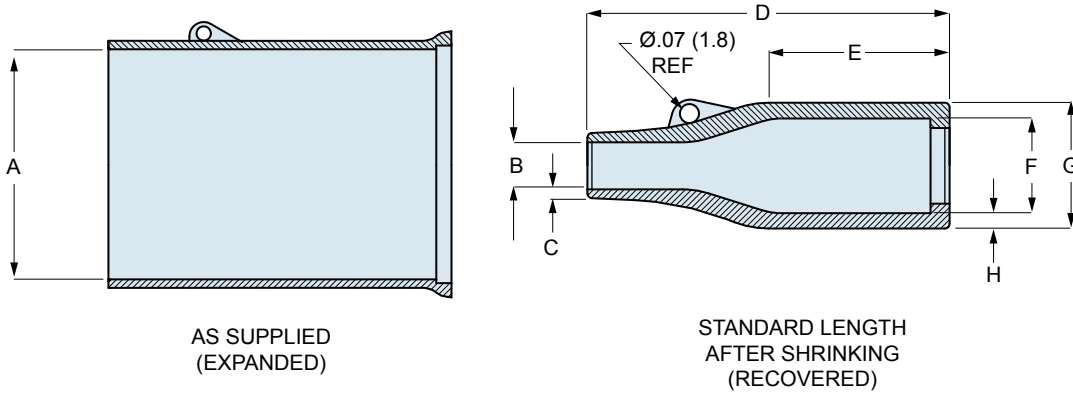

Boot Size	A Min.		B Max.		C ± 20%		D ± 10%		E Ref.		F Max.		G Ref.		H ± 30%	
	In.	mm.	In.	mm.	In.	mm.	In.	mm.	In.	mm.	In.	mm.	In.	mm.	In.	mm.
00	.354	9.0	.079	2.0	.028	0.7	.984	25.0	.551	14.0	.217	5.5	.295	7.5	.039	1.0
01	.472	12.0	.118	3.0	.028	0.7	.984	25.0	.551	14.0	.276	7.0	.362	9.2	.043	1.1
02	.669	17.0	.138	3.5	.028	0.7	1.181	30.0	.728	18.5	.276	7.0	.378	9.6	.051	1.3
03	.945	24.0	.197	5.0	.035	0.9	1.496	38.0	.748	19.0	.413	10.5	.520	13.2	.063	1.6
04	1.181	30.0	.236	6.0	.039	1.0	2.165	55.0	1.181	30.0	.551	14.0	.693	17.6	.071	1.8
05	1.260	32.0	.276	7.0	.047	1.2	2.638	67.0	1.299	33.0	.709	18.0	.850	21.6	.071	1.8
06	1.417	36.0	.335	8.5	.047	1.2	3.150	80.0	1.575	40.0	.866	22.0	.945	24.0	.079	2.0
07	1.693	43.0	.394	10.0	.051	1.3	3.898	99.0	2.165	55.0	1.102	28.0	1.276	32.4	.087	2.2
08	2.362	60.0	.591	15.0	.063	1.6	5.118	130.0	1.969	50.0	1.378	35.0	1.638	41.6	.130	3.3
09	2.600	66.0	.660	16.8	.080	2.0	6.690	170.0	3.540	90.0	1.750	44.5	2.050	52.0	.150	3.8

## Lipped Straight Shrink Boots- Part Marking, Raised Lettering

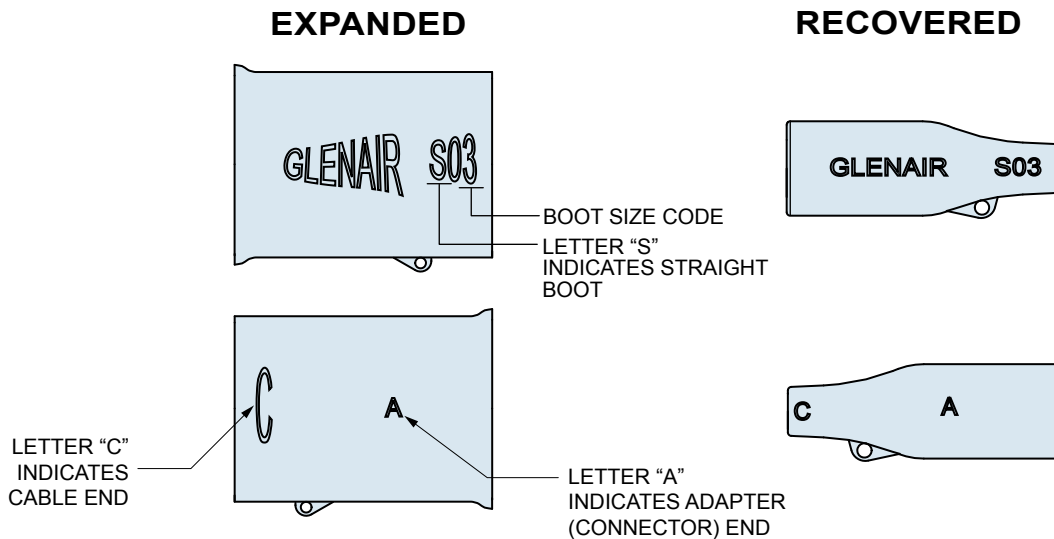

Dimensions in inches (millimeters) and are subject to change without notice.