

# 557-387 EMI/RFI Backshell Assembly for MIL-C-24308 Connectors

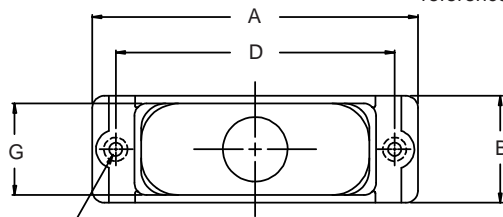

Metric dimensions (mm) are indicated in parentheses

**557-387**  
**EMI/RFI Backshell Assembly**  
**for MIL-C-24308 Connectors**

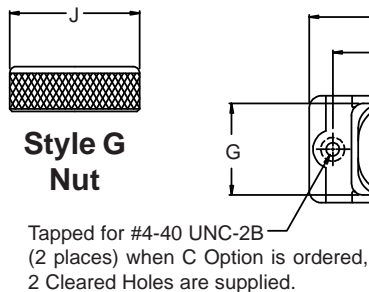
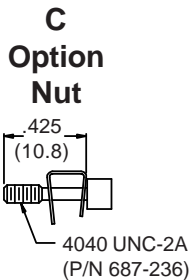
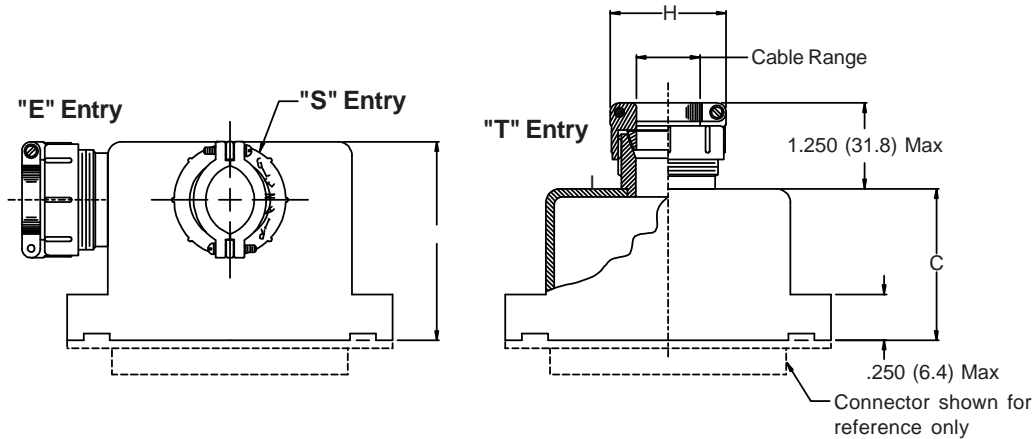
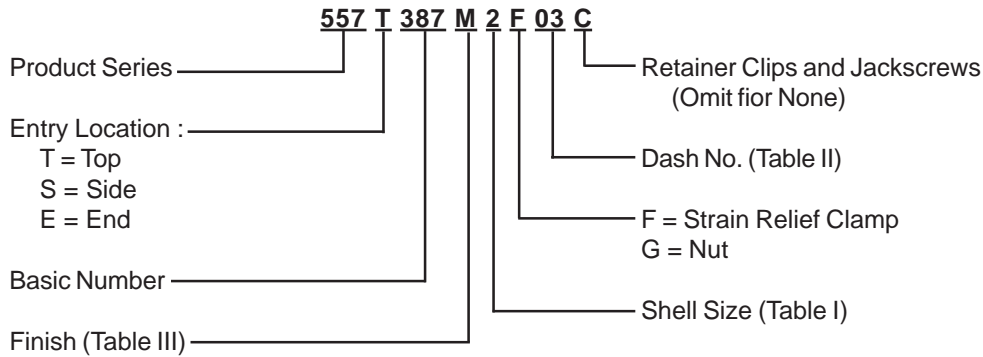

MIL-C-24308  
D-Subminiature

**TABLE I: CONNECTOR INTERFACE & BACKSHELL DIMENSIONS**

Shell Size	A Max	B	C	D ±.005 (0.1)	E	F	Max Dash No.
1	1.250 (31.8)	.530 (13.5)	.750 (19.1)	.984 (25.0)	1.880 (47.8)	.430 (10.9)	03
2	1.580 (40.1)	.530 (13.5)	.750 (19.1)	1.312 (33.3)	1.880 (47.8)	.430 (10.9)	03
3	2.130 (54.1)	.530 (13.5)	1.000 (25.4)	1.852 (47.0)	1.880 (47.8)	.430 (10.9)	03
4	2.770 (70.4)	.530 (13.5)	1.000 (25.4)	2.500 (63.5)	1.880 (47.8)	.430 (10.9)	03
5	2.680 (68.1)	.660 (16.8)	1.250 (31.8)	2.406 (61.1)	2.130 (54.1)	.560 (14.2)	04
6	2.770 (70.4)	.730 (18.5)	1.250 (31.8)	2.500 (63.5)	2.220 (56.4)	.630 (16.0)	05

**TABLE II: CABLE ENTRY**

Dash No.	H Max	J Max	Cable Range	
			Min	Max
02	.968 (24.6)	.781 (19.8)	.125 (3.2)	.250 (6.4)
03	1.046 (35.7)	.906 (23.0)	.250 (6.4)	.375 (9.5)
04	1.156 (29.4)	1.031 (26.2)	.312 (7.9)	.500 (12.7)
05	1.218 (30.9)	1.156 (29.4)	.437 (11.1)	.625 (15.9)

**TABLE III:  
FINISH OPTIONS**

Symbol	Finish
B	Cadmium Plate/Olive Drab
C*	Black Anodize
G*	Anodic Hard Coat
J	Gold Iridite over Cadmium Plate over Electroless Nickel
LF	Cadmium Plate/Bright over Electroless Nickel
M	Electroless Nickel
N	Cadmium Plate/Olive Drab over Electroless Nickel
NC	Zinc Cobalt/Dark Olive Drab
NF	Cadmium Plate/Olive Drab over Electroless Nickel
T	Cadmium Plate/Bright over Electroless Nickel
U**	Cadmium Plate/Black
ZN	Zinc-Nickel Alloy/Olive Drab

\*Anodize finish is not suitable for EMI shielding or grounding applications.  
\*\*Applicable to corrosion resisting steel backshells and accessories. Consult factory for other available finishes.

Metric dimensions (mm) are indicated in parentheses