



# 557-184 EMI/RFI Banding Backshell Assembly for MIL-C-24308 Connectors

**557 S 184 M 1 23**

Product Series \_\_\_\_\_  
 S = Side Entry \_\_\_\_\_  
 Basic Part Number \_\_\_\_\_

Dash No. (Table II) \_\_\_\_\_  
 Shell Size (Table I) \_\_\_\_\_  
 Finish (Table III) \_\_\_\_\_

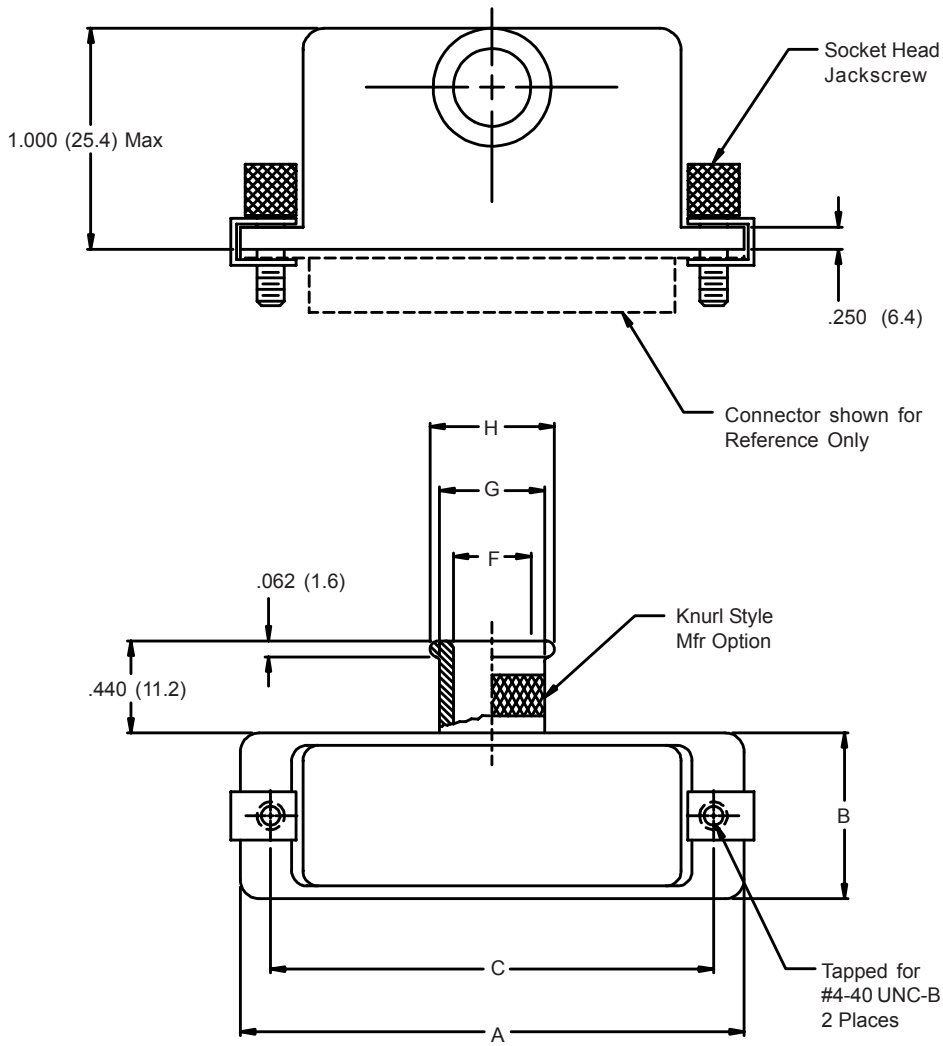

Metric dimensions (mm) are indicated in parentheses

**557-184**  
**EMI/RFI Banding Backshell Assembly**  
**for MIL-C-24308 Connectors**



MIL-C-24308  
D-Subminiature

**TABLE I: CONNECTOR INTERFACE DIMS**

Shell Size	A Max	B	C ±.005 (0.1)
1	1.250 (31.8)	.530 (13.5)	.984 (25.0)

**TABLE II: CABLE ENTRY**

Dash No.	F Dia	G Dia	H Dia
23	.250 (6.4)	.340 (8.6)	.370 (9.4)

**TABLE III: FINISH OPTIONS**

Symbol	Finish
B	Cadmium Plate/Olive Drab
C*	Black Anodize
G*	Anodic Hard Coat
J	Gold Iridite over Cadmium Plate over Electroless Nickel
LF	Cadmium Plate/Bright over Electroless Nickel
M	Electroless Nickel
N	Cadmium Plate/Olive Drab over Electroless Nickel
NC	Zinc Cobalt/Dark Olive Drab
NF	Cadmium Plate/Olive Drab over Electroless Nickel
T	Cadmium Plate/Bright over Electroless Nickel
U**	Cadmium Plate/Black
ZN	Zinc-Nickel Alloy/Olive Drab

\*Anodize finish is not suitable for EMI shielding or grounding applications.  
\*\*Applicable to corrosion resisting steel backshells and accessories. Consult factory for other available finishes.

Metric dimensions (mm) are indicated in parentheses