



557-178
D-Subminiature Non-EMI
Strain-Relief Solid Backshell

557 T 178 M 2 F0 B 1 F

Basic Part No. ————
 Cable Entry Style ————
 T = Top
 Basic Part Number ————
 Finish Symbol (Page 3) ————
 Shell Size (Table I) ————

F = Strain Relief
 G = Gland Nut
 0 = Without EMI Gasket,
 1 = With EMI Gasket
 Jackscrew Type (Page A-4)
 Receptacle Mounting (Table II)
 F0 = Front Mounting
 R1-R9 = Rear Mounting

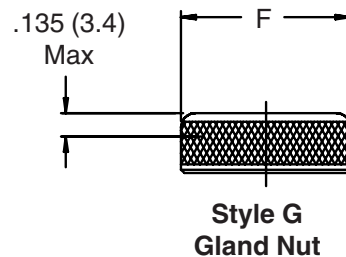
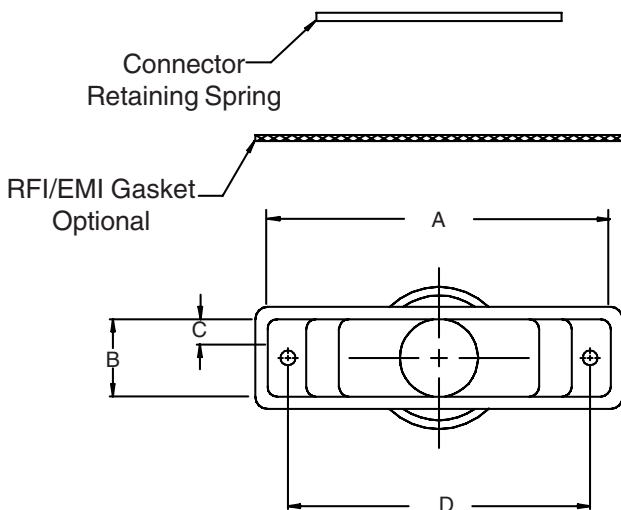
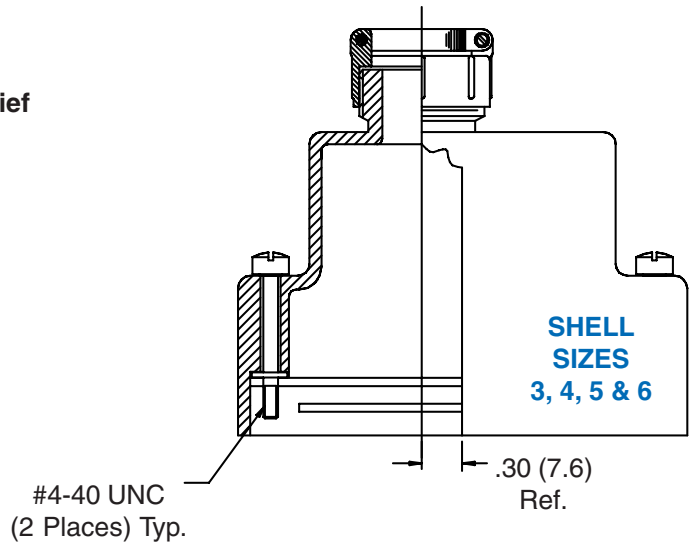
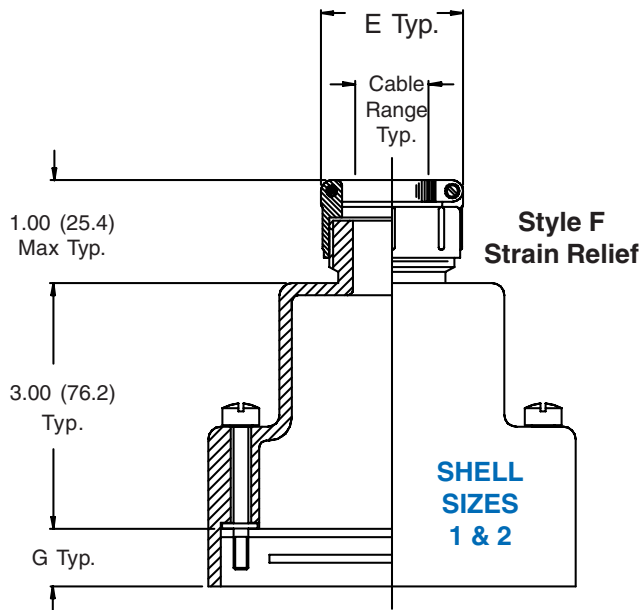

557-178
D-Subminiature Non-EMI
Strain-Relief Solid Backshell



MIL-C-24308
D-Subminiature

TABLE I: SHELL SIZE & CONNECTOR INTERFACE DIMENSIONS

Shell Size	Com'l Shell Size Ref	A		B		C		D	
								±.005	(.1)
1	E/09	1.241	(31.5)	.515	(13.0)	.258	(6.6)	.984	(25.0)
2	A/15	1.569	(39.9)	.515	(13.0)	.258	(6.6)	1.312	(33.3)
3	B/25	2.116	(53.7)	.515	(13.0)	.258	(6.6)	1.852	(47.0)
4	C/37	2.757	(70.0)	.515	(13.0)	.258	(6.6)	2.500	(63.5)
5	D/50	2.663	(67.6)	.625	(15.9)	.313	(8.0)	2.406	(61.1)
6	F/104	2.757	(70.0)	.688	(17.5)	.344	(8.7)	2.500	(63.5)

TABLE I (Continued): CABLE ENTRY & GLAND NUT

Shell Size	Com'l Shell Size Ref	E Max	F Max	Cable Range	
				Min	Max
1	E/09	.843 (21.4)	.625 (15.9)	.125 (3.2)	.250 (6.4)
2	A/15	.968 (24.6)	.750 (19.1)	.156 (4.0)	.375 (9.5)
3	B/25	1.156 (29.4)	1.000 (25.4)	.280 (7.1)	.500 (12.7)
4	C/37	1.156 (29.4)	1.000 (25.4)	.280 (7.1)	.500 (12.7)
5	D/50	1.218 (30.9)	1.250 (31.8)	.375 (9.5)	.625 (15.9)
6	F/104	1.468 (37.3)	1.375 (34.9)	.625 (15.9)	.875 (22.2)

TABLE II: RECEPTACLE MOUNTING

Dash No.	Panel Thickness		G	
R1	.031	(.8)	.247	(6.3)
R2	.047	(1.2)	.231	(5.9)
R3	.062	(1.6)	.216	(5.5)
R4	.093	(2.4)	.185	(4.7)
R5	.104	(2.6)	.174	(4.4)
R6	.125	(3.2)	.153	(3.9)
R7	.156	(4.0)	.125	(3.2)
R8	.135	(3.4)	.140	(3.6)
F0	N/A		.305	(7.7)

1. Metric dimensions (mm) are indicated in parentheses.
2. **DO NOT USE CONNECTORS WITH FLOAT MOUNTINGS.**
3. For front mount, mating connector must be mounted to panel using M24308/26 female screwlocks. For rear mount, use Glenair GK134.