



557-018 EMI/RFI D-Subminiature Split Backshell Crimp Ring Shield Termination with Shrink Boot Groove

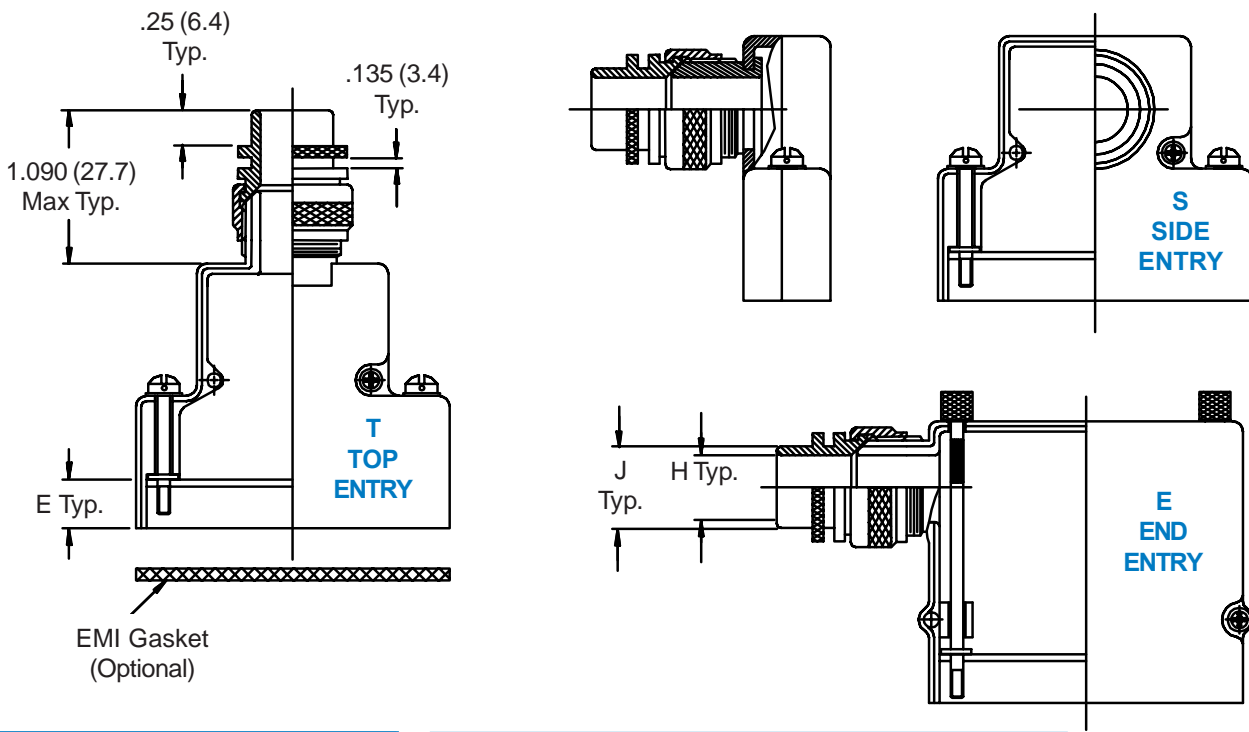
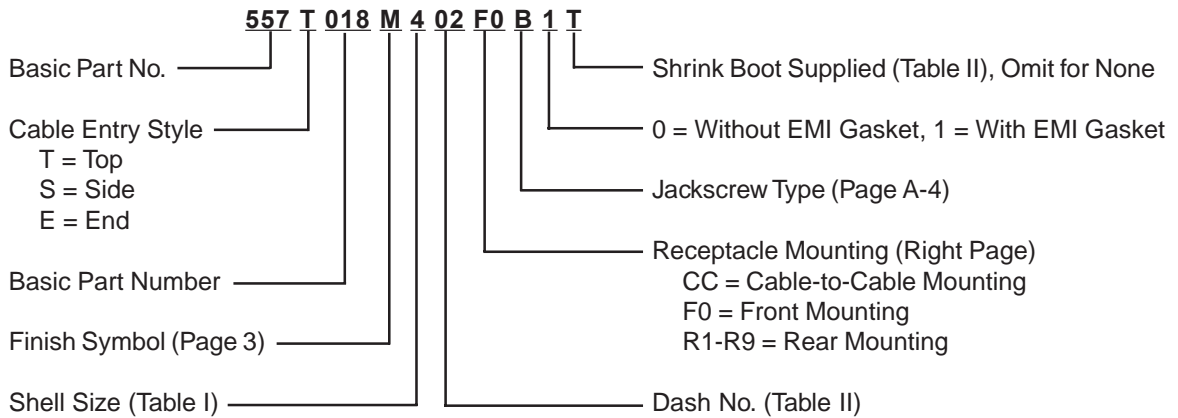

TABLE I: SHELL SIZE		
Shell Size	Com'l Shell Size Ref	Max Entry Dash No. Table II
1	E/09	02
2	A/15	04
3	B/25	05
4	C/37	05
5	D/50	07
6	F/104	07

TABLE II: CABLE ENTRY & SHRINK BOOT			
Dash No.	H Dia	J Dia	Shrink Boot
01	.125 (3.2)	.250 (6.4)	n/a
02	.250 (6.4)	.375 (9.5)	202K121-25-0
03	.312 (7.9)	.438 (11.1)	202K121-25-0
04	.375 (9.5)	.500 (12.7)	202K132-25-0
05	.420 (10.7)	.540 (13.7)	202K132-25-0
06	.500 (12.7)	.625 (15.9)	202K142-25-0
07	.562 (14.3)	.688 (17.5)	202K153-25-0

1. Metric dimensions (mm) are indicated in parentheses.
2. **DO NOT USE CONNECTORS WITH FLOAT MOUNTINGS.**
3. Crimp Ring Not Supplied.

D-Subminiature Split Backshells Standard Dimensions



MIL-C-24308
D-Subminiature

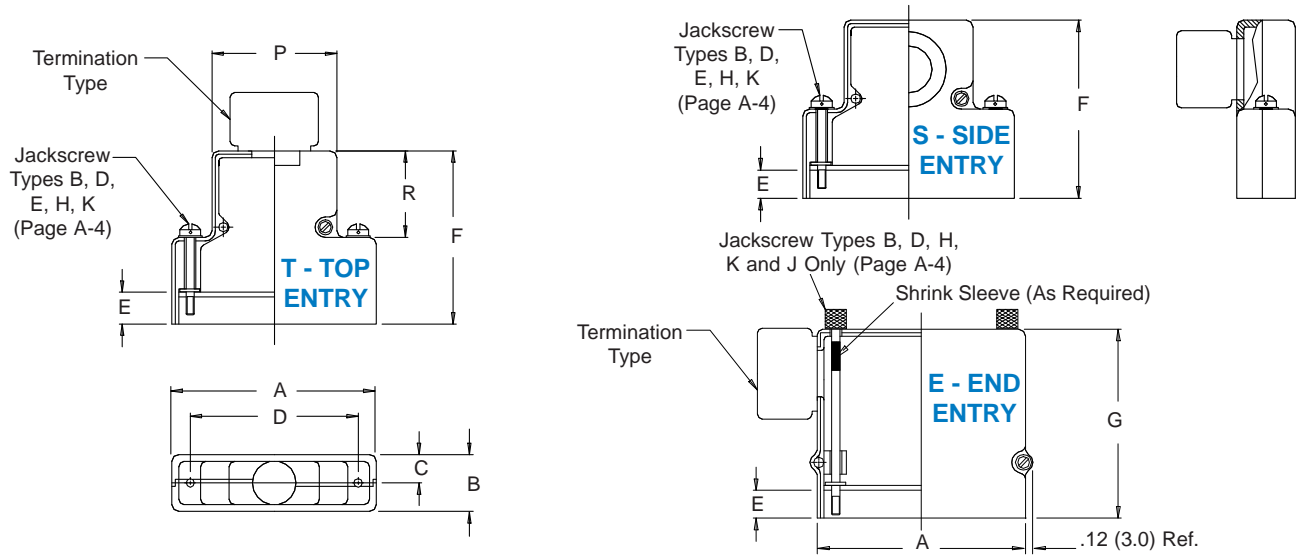

COMMON BACKSHELL DIMENSIONS

Shell Size	Com'l Shell Size Ref	A Max	B Max	C Ref.	D		P	R Ref
					±.005	(.1)		
1	E/09	1.393 (35.4)	.624 (15.8)	.312 (7.9)	.984 (25.0)	.730 (18.5)	.719 (18.3)	
2	A/15	1.706 (43.3)	.624 (15.8)	.312 (7.9)	1.312 (33.3)	1.050 (26.7)	.719 (18.3)	
3	B/25	2.265 (57.5)	.624 (15.8)	.312 (7.9)	1.852 (47.0)	1.594 (40.5)	.938 (23.8)	
4	C/37	2.900 (73.7)	.624 (15.8)	.312 (7.9)	2.500 (63.5)	2.240 (56.9)	.938 (23.8)	
5	D/50	2.800 (71.1)	.750 (19.1)	.375 (9.5)	2.406 (61.1)	2.140 (54.4)	.938 (23.8)	
6	F/104	2.900 (73.7)	.844 (21.4)	.422 (10.7)	2.500 (63.5)	2.240 (56.9)	1.094 (27.8)	

CABLE MOUNTING DIMENSIONS

Dash No.	Panel Thickness	E	F ± .031 (0.79)			G ± .031 (0.79)	
			Sizes 1 & 2	Sizes 3 - 5	Size 6	Sizes 1 & 2	Sizes 3 - 5
CC	n/a	.174 (4.4)	1.451 (36.9)	1.671 (42.4)	1.820 (46.2)	1.583 (40.2)	1.831 (46.5)
F0	n/a	.343 (8.7)	1.625 (41.3)	1.844 (46.8)	2.000 (50.8)	1.750 (44.5)	2.000 (50.8)
R1	.031 (.8)	.247 (6.3)	1.525 (38.7)	1.745 (44.3)	1.890 (48.0)	1.656 (42.1)	1.904 (48.4)
R2	.047 (1.2)	.231 (5.9)	1.509 (38.3)	1.728 (43.9)	1.875 (47.6)	1.640 (41.7)	1.888 (48.0)
R3	.062 (1.6)	.216 (5.5)	1.500 (38.1)	1.720 (43.7)	1.860 (47.2)	1.625 (41.3)	1.873 (47.6)
R4	.093 (2.4)	.185 (4.7)	1.470 (37.3)	1.690 (42.9)	1.829 (46.5)	1.594 (40.5)	1.842 (46.8)
R5	.104 (2.6)	.174 (4.4)	1.451 (36.9)	1.671 (42.4)	1.820 (46.2)	1.583 (40.2)	1.831 (46.5)
R6	.125 (3.2)	.153 (3.9)	1.430 (36.3)	1.650 (41.9)	1.798 (45.7)	1.563 (39.7)	1.811 (46.0)
R7	.156 (4.0)	.125 (3.2)	1.400 (35.6)	1.620 (41.1)	1.767 (44.9)	1.531 (38.9)	1.781 (45.2)
R8	.135 (3.4)	.140 (3.6)	1.417 (36.0)	1.637 (41.6)	1.805 (45.8)	1.550 (39.4)	1.798 (45.7)
R9	.188 (4.8)	.094 (2.4)	1.368 (34.7)	1.590 (40.4)	1.740 (44.2)	1.500 (38.1)	1.750 (44.5)

1. Metric dimensions (mm) are indicated in parentheses.