

500-024 M 1

Basic Part No. _____
Finish Symbol (Page 3) _____
Shell Size (Table I) _____

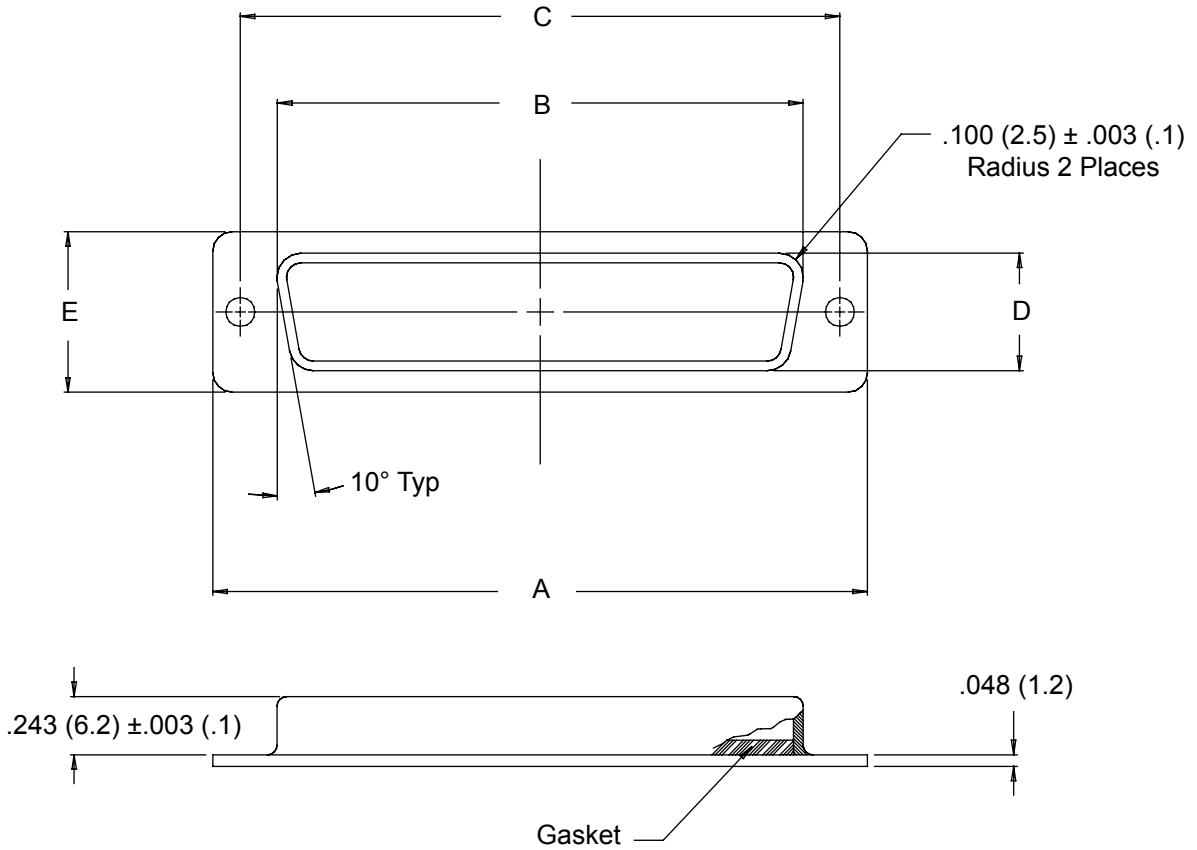

TABLE I: SHELL SIZE & STOWAGE PLUG DIMENSIONS

Shell Size	Com'l Shell Size Ref	A		B		C		D Max	E
		Max	±.005 (.1)	Max	±.005 (.1)	Max	±.005 (.1)		
1	E/09	1.213 (30.8)	.648 (16.5)	.984 (25.0)	.316 (8.0)	.494 (12.5)			
2	A/15	1.541 (39.1)	.976 (24.8)	1.312 (33.3)	.316 (8.0)	.494 (12.5)			
3	B/25	2.088 (53.0)	1.516 (38.5)	1.852 (47.0)	.316 (8.0)	.494 (12.5)			
4	C/37	2.729 (69.3)	2.164 (55.0)	2.500 (63.5)	.316 (8.0)	.494 (12.5)			
5	D/50	2.635 (66.9)	2.069 (52.6)	2.406 (61.1)	.428 (10.9)	.605 (15.4)			
6	F/104	2.729 (69.3)	2.194 (55.7)	2.500 (63.5)	.490 (12.4)	.668 (17.0)			