

CONNECTOR DESIGNATORS
A-B*-C-D-E-F
G-H-J-K-L-S
 * Conn. Desig. B See Note 3
DIRECT COUPLING

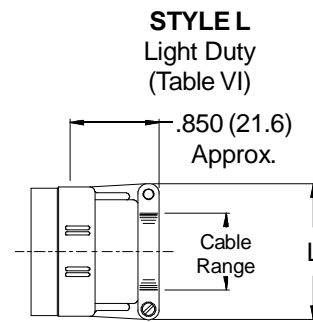

400-002
TAG® Ring Backshell
 with Strain Relief
 Direct Coupling - Standard Profile

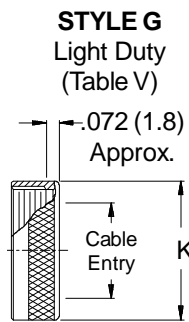
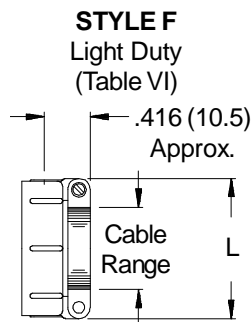
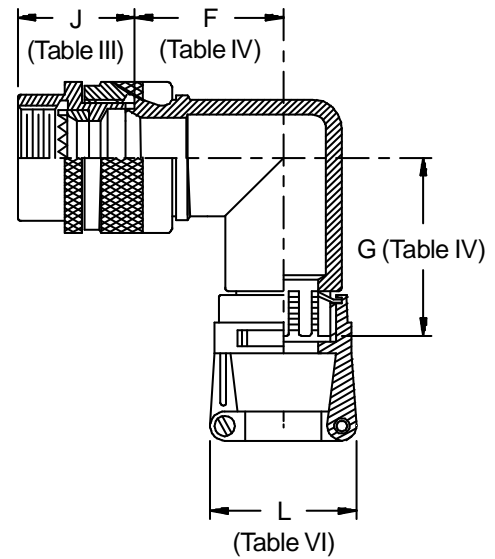
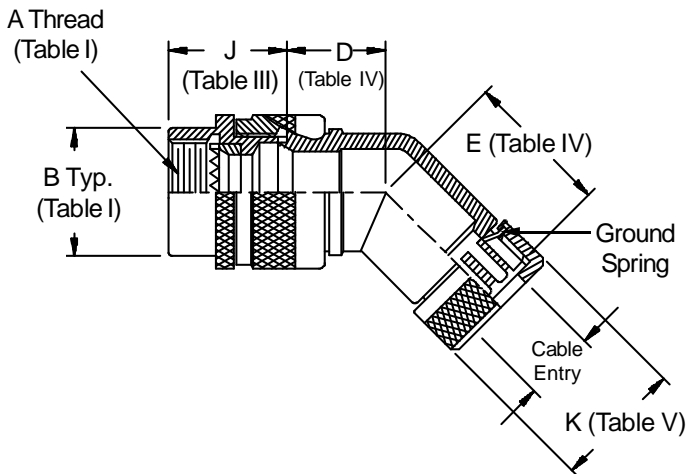
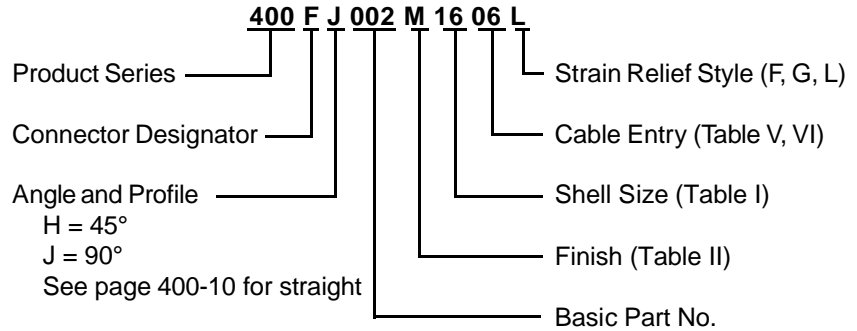

TABLE III: FRONT ADAPTER

Shell Size	J Max - Conn. Designator		
	A-E-F	D-B-G-K	C
	J-H-L-S		
08/09	1.180 (30.0)	1.250 (31.8)	
10/11	1.180 (30.0)	1.250 (31.8)	
12/13	1.180 (30.0)	1.250 (31.8)	1.735 (44.1)
14/15	1.180 (30.0)	1.250 (31.8)	1.915 (48.6)
16/17	1.380 (35.0)	1.560 (39.6)	1.915 (48.6)
18/19	1.380 (35.0)	1.560 (39.6)	1.915 (48.6)
20/21	1.380 (35.0)	1.560 (39.6)	1.915 (48.6)
22/23	1.380 (35.0)	1.560 (39.6)	1.915 (48.6)
24/25	1.380 (35.0)	1.560 (39.6)	1.915 (48.6)
28/29	1.610 (40.9)	1.560 (39.6)	1.915 (48.6)
32/33	1.610 (40.9)	1.750 (44.5)	1.915 (48.6)
36	1.610 (40.9)	1.750 (44.5)	1.915 (48.6)
40	1.610 (40.9)	2.190 (55.6)	1.915 (48.6)

See inside back cover
 fold-out or pages 13 and
 14 for Tables I and II.

1. Metric dimensions (mm) are indicated in parentheses.
2. Cable range is defined as the accommodations range for the wire bundle or cable. Dimensions shown are not intended for inspection criteria.
3. When using Connector Designator B refer to pages 18 and 19 for part number development.

TABLE IV: ELBOW DIMENSIONS

Dash No.	D Max	E Max	F Max	G Max
02	.639 (16.2)	1.510 (38.4)	.750 (19.1)	1.620 (41.1)
03	.664 (16.9)	1.540 (39.1)	.810 (20.6)	1.680 (42.7)
04	.688 (17.5)	1.560 (39.6)	.870 (22.1)	1.740 (44.2)
05	.705 (17.9)	1.590 (40.4)	.920 (23.4)	1.810 (46.0)
06	.732 (18.6)	1.610 (40.9)	.980 (24.9)	1.870 (47.5)
07	.748 (19.0)	1.620 (41.1)	1.020 (25.9)	1.890 (48.0)
08	.773 (19.6)	1.640 (41.7)	1.080 (27.4)	1.950 (49.5)
09	.800 (20.3)	1.680 (42.7)	1.140 (29.0)	2.030 (51.6)
10	.823 (20.9)	1.710 (43.4)	1.200 (30.5)	2.100 (53.3)

TABLE V: CABLE ENTRY

Dash No.	K Max	Cable Entry Max
02	.545 (13.8)	.250 (6.4)
03	.670 (17.0)	.375 (9.5)
04	.795 (20.2)	.500 (12.7)
05	.920 (23.4)	.625 (15.9)
06	1.045 (26.5)	.750 (19.1)
07	1.170 (29.7)	.875 (22.2)
08	1.295 (32.9)	1.000 (25.4)
09	1.420 (36.1)	1.125 (28.6)
10	1.670 (42.4)	1.250 (31.8)

TABLE VI: CABLE ENTRY

Dash No.	L Max	Cable Range	
		Min	Max
02	.968 (24.6)	.125 (3.2)	.250 (6.4)
03	1.046 (26.6)	.250 (6.4)	.375 (9.5)
04	1.156 (29.4)	.250 (6.4)	.500 (12.7)
05	1.218 (30.9)	.375 (9.5)	.625 (15.9)
06	1.343 (34.1)	.500 (12.7)	.750 (19.1)
07	1.468 (37.3)	.625 (15.9)	.875 (22.2)
08	1.593 (40.5)	.625 (15.9)	1.000 (25.4)
09	1.718 (43.6)	.750 (19.1)	1.125 (28.6)
10	1.843 (46.8)	.875 (22.2)	1.250 (31.8)