

**CONNECTOR
 DESIGNATOR**

G

**ROTATABLE
 COUPLING**

**TYPE B INDIVIDUAL
 AND/OR OVERALL
 SHIELD TERMINATION**

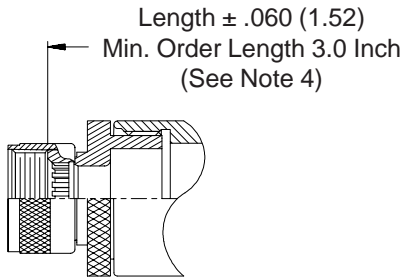
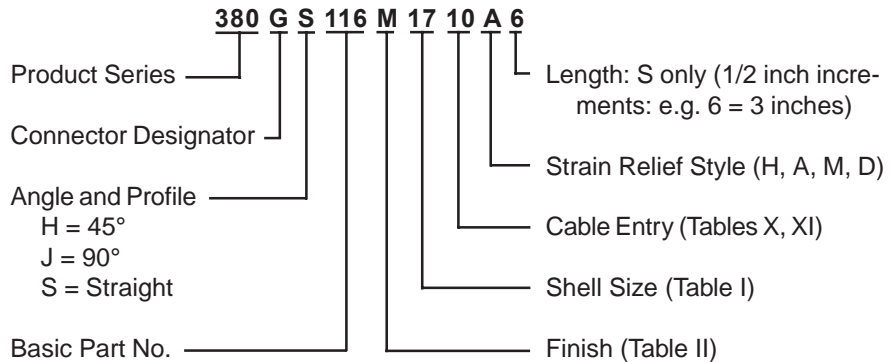

**STYLE 2
 (STRAIGHT
 See Note 1)**

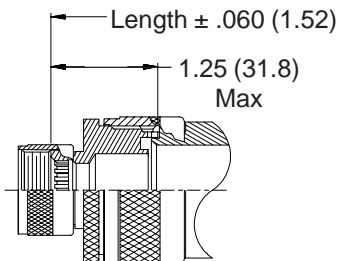
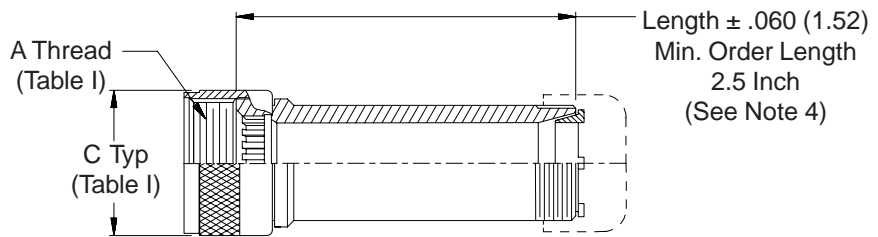

**STYLE 2
 (45° & 90°
 See Note 1)**

